

MARINE SEWAGE TREATMENT SYSTEMS



IMO MEPC.227(64)
SEWAGE TREATMENT PLANTS

&

COAST GUARD APPROVED TYPE II
MARINE SANITATION DEVICES

3380 SW 11th Avenue
Fort Lauderdale, Florida 33315
Phone: +1 954-581-6996
Fax: +1 954-587-0403



HEADHUNTER 
WWW.HEADHUNTERINC.COM

MARINE SEWAGE TREATMENT SYSTEMS

Headhunter's team of engineers, fabricators, and wastewater specialists combine to deliver the most innovative and efficient treatment solutions in the categories of Sewage Treatment Plant, Physical Chemical Marine Sanitation Device, and Biological Marine Sanitation Device. Whether it's a space-saving modular unit designed for the bilge of a large megayacht, or a skid-mounted turnkey package complete with all accessories for a jack up rig or fixed platform the Headhunter team is ready to take on the challenge.

SEWAGE TREATMENT PLANT – IMO MEPC.227(64)

The TIDALWAVE HMX® Sewage Treatment Plant (STP) are approved for worldwide compliance with the IMO Resolution MEPC.227(64). Designed for quick starts and stops with the push of a button, the TIDALWAVE HMX system utilizes chemically enhanced coagulation and flocculation in a biological clarifier, followed by electrolytic through Auto Clor Sodium Hypochlorite Generator in a breakpoint disinfection, and tertiary polishing with granular activated carbon with optional bisulfite injection (at user's request).

PGs 2-14



CUSTOM TREATMENT SYSTEMS

PGs 15-18

PHYSICAL CHEMICAL MARINE SANITATION DEVICE

TIDALWAVE HMX® are U.S. Coast Guard certified Type II Marine Sanitation Devices (MSDs) in accordance with 33CFR Part 159. These systems are recommended for US Flagged vessels over 65 feet long. These systems provide automated state of the art processing of onboard sewage. Designed for quick starts and stops with the push of a button, the TIDALWAVE HMX® system uses chemical oxidation, hydro-maceration and patented cross flow separation techniques to thoroughly destroy influent biomass.

PGs 19-20



BIOLOGICAL MARINE SANITATION DEVICE

TIDALWAVE® aerobic biological sewage treatment systems are U.S. Coast Guard certified Type II Marine Sanitation Devices (MSD) in accordance with 33CFR Part 159. These systems are recommended for US Flagged vessels over 65 feet long. The biological process is simple, reliable, and efficient. The system makes good environmental sense by working with nature to accelerate the normal biological process.

PGs 21-16



CONTROL PANELS

PGs 23-24

WASTE WATER ACCESSORIES

PGs 25-26

WASTE WATER PUMPS

PGs 27-29

HOSE

PG 29

CONSUMABLES

PG 30

The Definition of Sewage Treatment Plant (STP)

Sewage Treatment Plants are governed by the International Maritime Organization, IMO. The IMO is the United Nations agency responsible for the safety and security of shipping and the prevention of marine pollution by ships.

The International Convention for the Prevention of Pollution from Ships (MARPOL) is the main convention covering the prevention of pollution by ships. MARPOL currently includes six Annexes covering oil, noxious liquids, harmful substances, sewage, garbage, and air pollution. Annex IV covers pollution by sewage and entered into force on 27 September 2008.

According to Regulation 2 the provisions of Annex IV apply to the following ships engaged in international travel;

- Ships larger than 400 gross tonnage
- Ships less than 400 gross tonnage certified to carry more than 15 persons, where a “person” is defined as a member of the crew and passengers.

According to Regulation 9, every ship which is required to comply with Annex IV shall be equipped with one of the following sewage systems;

- A sewage treatment plant type approved according to the performance standards of MEPC.227(64).
- A temporary sewage storage tank and a comminuting and disinfecting system.
- A sewage holding tank equipped with visual level indication of the capacity to the satisfaction of the Administration for the retention of all sewage.

According to Regulation 11, the discharge of sewage into the sea is prohibited except when;

- The ship has in operation an approved sewage treatment plant or
- The ship is discharging comminuted & disinfected sewage using an approved system more than 3 miles from nearest land or
- The sewage is discharged more than 12 miles from the nearest land at a moderate rate when the speed of the vessel is greater than 4 knots

US Flagged vessels are obliged to comply with the Clean Water Act and must install a US Coast Guard Approved Marine Sanitation Device (MSD). The Tidal Wave HMX 6000 to 9000 series are US Coast Guard Approved MSDs according to 33CFR Part 159 and IMO type approved Sewage Treatment Plants according to IMO resolution MEPC.227(64).

Tidalwave HMX STP Specifications

	Hydraulic Loading Capacity		Organic Loading Capacity		Maximum Personnel Complement	
	US Gal/day	liter/day	lb/day	kg/day	Black Water Only	Black & Grey Water
TW-HMX-6*01	600	2300	4.8	2.2	27	13
TW-HMX-6*01LP						
TW-HMX-6*02	1,200	4500	9.6	4.4	53	27
TW-HMX-6*02LP						
TW-HMX-6*03	1,800	6800	14.4	6.5	80	40
TW-HMX-6*03LP						
TW-HMX-6*04	2,000	7600	16	7.3	89	44
TW-HMX-6*04LP						
TW-HMX-7*05	5,000	18,900	40	18.1	222	111
TW-HMX-8*03	10,000	37,900	80	36.3	444	222
TW-HMX-8*05	15,000	56,800	120	54.4	667	333
TW-HMX-9*02	20,000	75,700	160	72.6	889	444

*Substitute * for construction material*

0 = HDPE - Plastic process tanks

1 = Aluminum - 5086 Marine grade aluminum / epoxy coating

2 = Steel - A36 Alloy (other alloys available upon request) / epoxy coating



- USCG CERTIFIED AND BUREAU VERITAS APPROVED TO IMO MEPC.227(64) STANDARD FOR WORLD WIDE ACCEPTANCE
- PATENTED CROSS-FLOW SEPARATION TECHNIQUE
- LOW MAINTENANCE
- QUIET, ODOR FREE PERFORMANCE
- EASY & AUTOMATIC OPERATION WITH PROGRAMMABLE FEATURES
- CONSTRUCTED OF TOUGH, CORROSION RESISTANT MATERIALS
- SMALL FOOTPRINT & LIGHTWEIGHT DESIGN
- CAPACITIES UP TO 75,700 LITERS PER DAY
- PLC WITH COLOR TOUCH SCREEN DISPLAYS AND AUTOMATES ALL VESSEL WASTE TANKS INTO MSD
- PLC AUTOMATION AVAILABLE

TIDALWAVE HMX Sewage Treatment Plant

The TIDALWAVE HMX® compact sewage treatment systems are U.S. Coast Guard certified Type II Marine Sanitation Devices that are also IMO Approved for worldwide compliance with MEPC.227(64). Standard models are available to treat up to 20,000 US Gallons per day (75.7 cubic meters per day). These systems provide automated processing of onboard sewage.

Designed for quick starts and stops with the push of a button, the TIDALWAVE HMX system uses flocculant settling, chemical oxidation, hydro-maceration and patented crossflow separation techniques to thoroughly destroy influent biomass. This is all done without the need for an additional sludge retention tank onboard.

The optional Electrolytic system generates sodium hypochlorite on location from seawater or brine, thus eliminating consumable chlorine during operation. The six-stage treatment system provides trouble free treatment of black and gray water with a sterile effluent for disposal. The process allows the treatment technique to be customized after installation for varying hydraulic and organic loading conditions, or to meet varying performance standards in different areas. These systems are provided in polyethylene, marine grade aluminum or steel construction with a durable epoxy coating for superior corrosion protection.



TW-HMX Sewage Treatment Plant Typical System Diagram

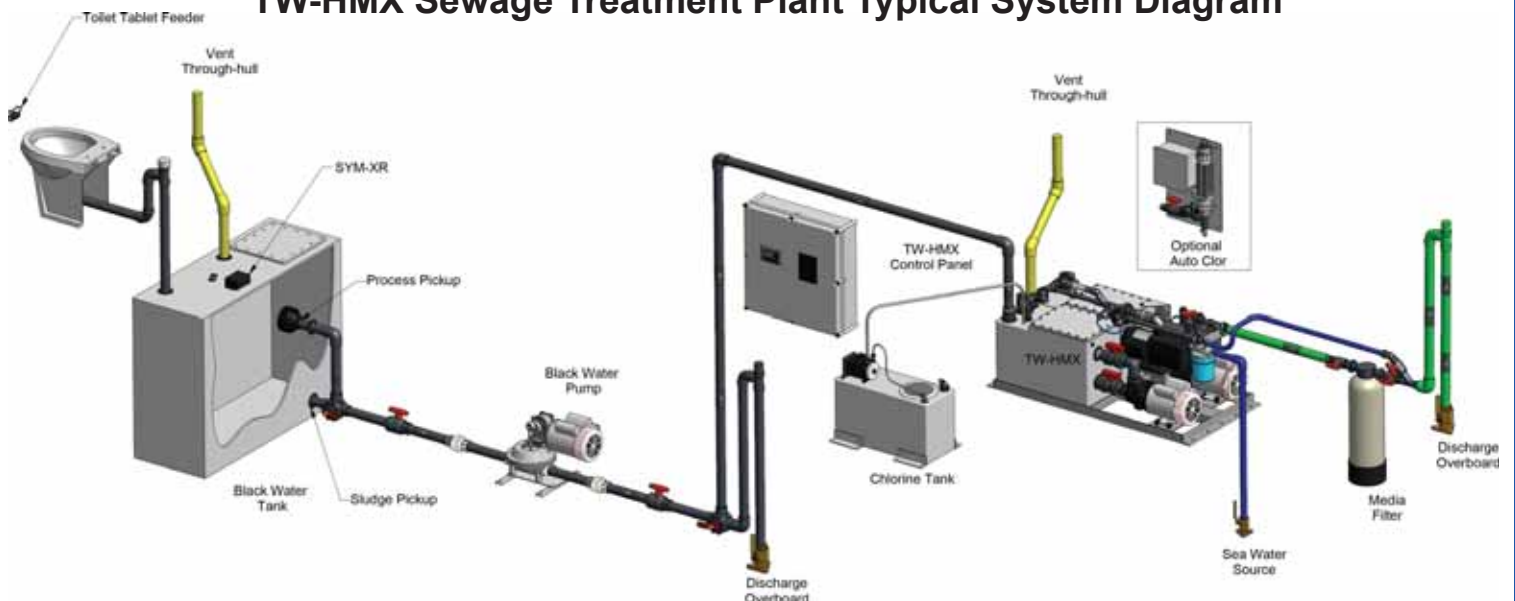

TW-HMX-6001

Standard Specifications

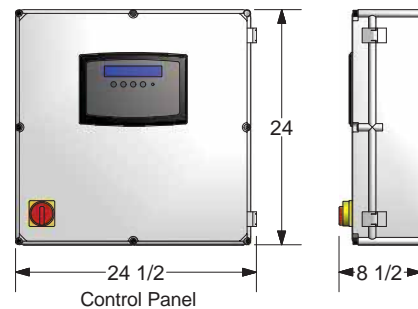
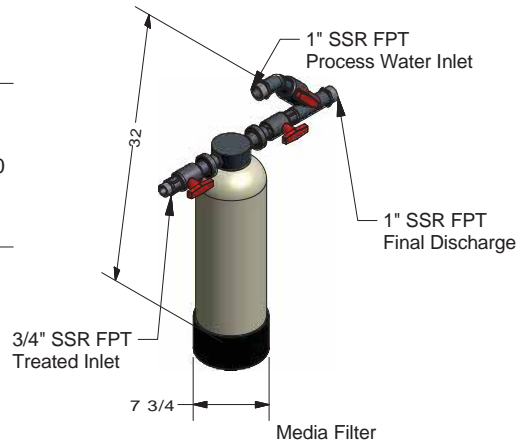
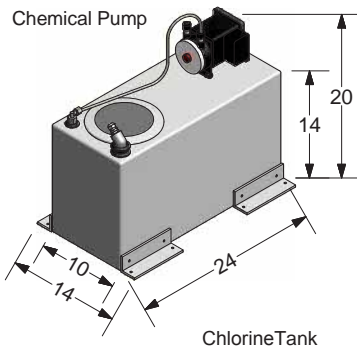
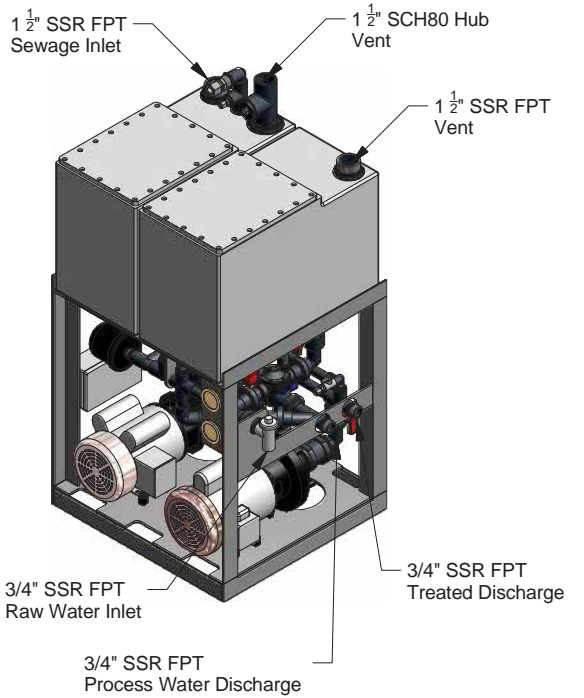
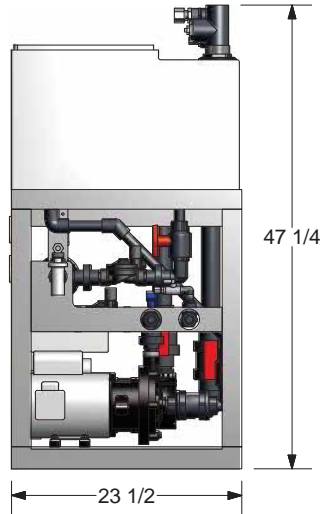
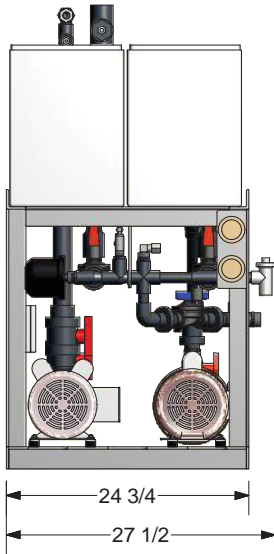
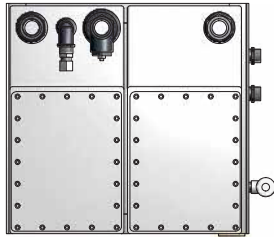

Rated Capacity:
Hydraulic Load: 600 Gallons per day
Organic load: 2.2 Kg/day

Dry Weight: 300 Lbs.
Max Operational Weight: 1000 Lbs.

Sewage Inlet: 1.5" SSR FPT (Stainless Steel Reinforced Female Pipe Thread)

Discharge: 3/4" SSR FPT
Vents: 1.5" SSR FPT, 1.5" SCH80 Hub
Raw Water Inlet: 3/4" SSR FPT

Construction Method: 1/4" 5083 Aluminum and HDPE
Coating: 2 Part Urethane
Maximum Test Pressure: 5psi (207mbar)
Operating temperature: 32°F-120°F (0°C-49°C)
Max Pitch/Roll Angle: 22.5° Maximum

Overall Dimensions:
Length: 27.5" (699mm)
Width: 23.5" (597mm)
Height: 47.25" (1200mm)

System Power

Input Power: 110-120VAC, 1Ø, 60hz
220-240VAC, 1Ø, 50/60hz
208-230VAC, 3Ø, 60hz
380-415VAC, 3Ø, 50hz
460-480VAC, 3Ø, 60hz

TW-HMX-6001LP

Standard Specifications

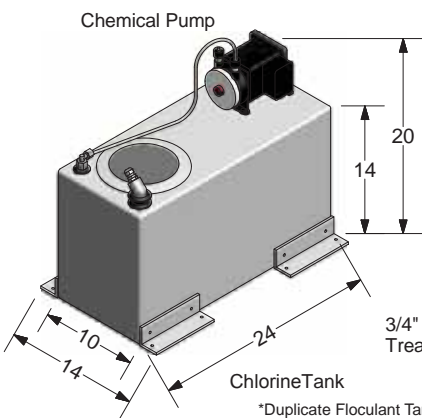
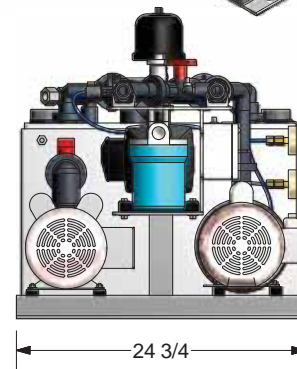
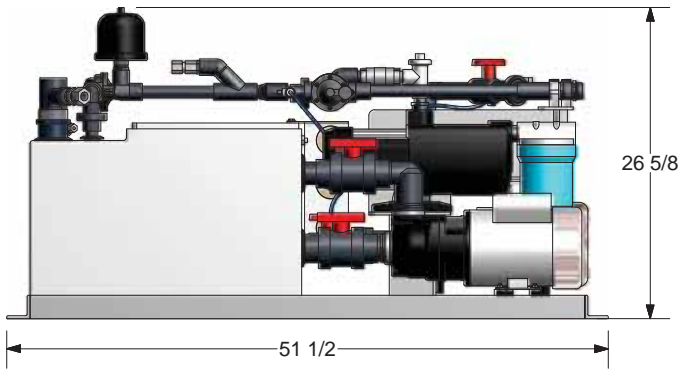
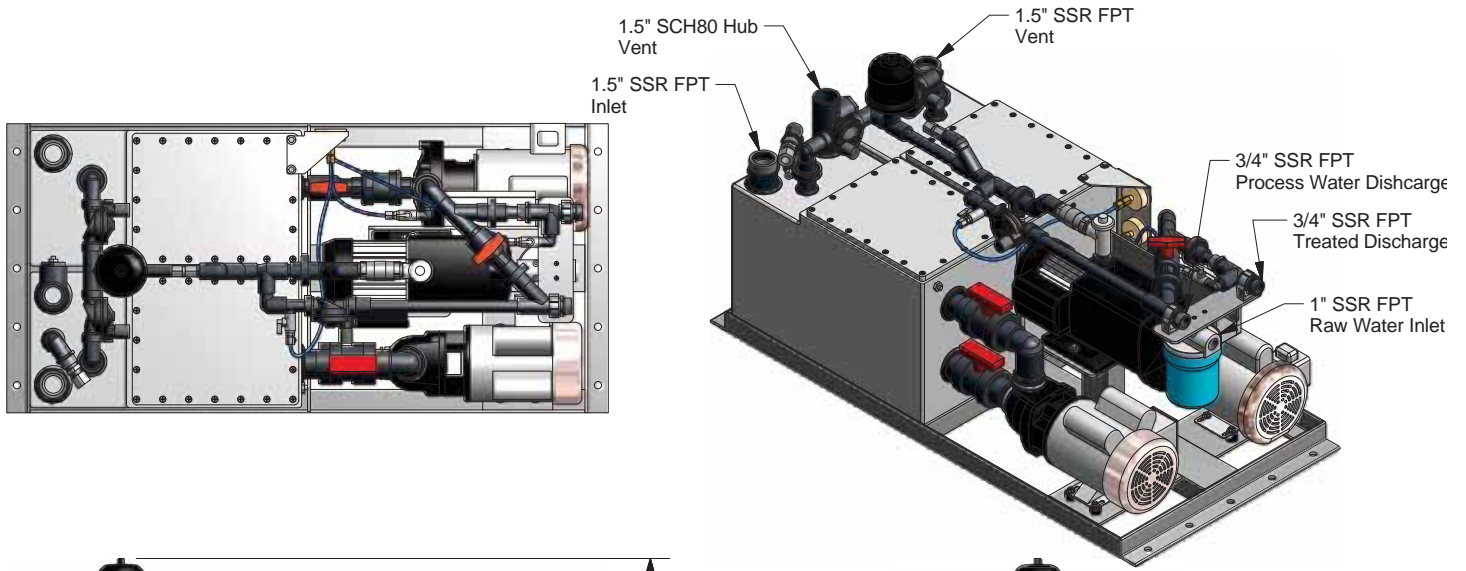

*Duplicate Flocculant Tank
May be required

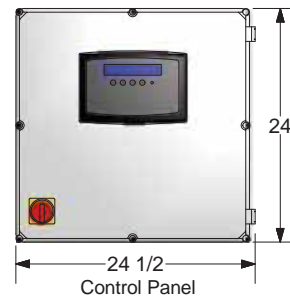
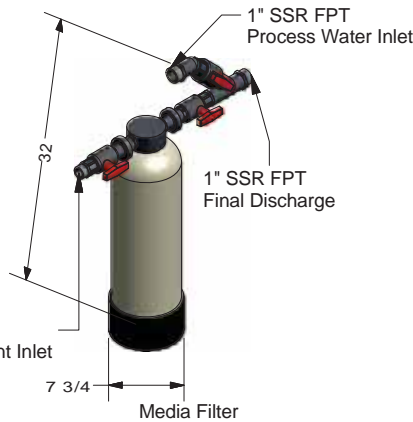

Rated Capacity: 600 Gallons per day
Hydraulic Load: 2.2 Kg/day
Organic load:

Overall Dimensions:
Length: 51.5" (1308mm)
Width: 24.75" (629mm)
Height: 26.625 (676mm)

System Power

Input Power: 110-120VAC, 1Ø, 60hz
220-240VAC, 1Ø, 50/60hz
208-230VAC, 3Ø, 60hz
380-415VAC, 3Ø, 50hz
460-480VAC, 3Ø, 60hz

Dry Weight: 100 Lbs.
Max Operational Weight: 450 Lbs.

Sewage Inlet: 1.5" SSR FPT (Stainless Steel Reinforced Female Pipe Thread)

Discharge: 3/4" SSR FPT
Vents: 1.5" SSR FPT 1.5" SCH80 Hub
Raw Water Inlet: 1" SSR FPT

Construction Method: 1/4" 5083 Aluminum and HDPE
Coating: 2 Part Urethane
Maximum Test Pressure: 5psi (207mbar)
Operating temperature: 32°F-120°F (0°C-49°C)
Max Pitch/Roll Angle: 22.5° Maximum

TW-HMX-6004

Standard Specifications

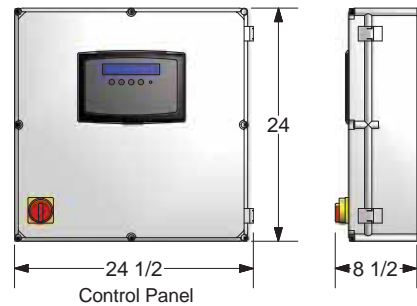
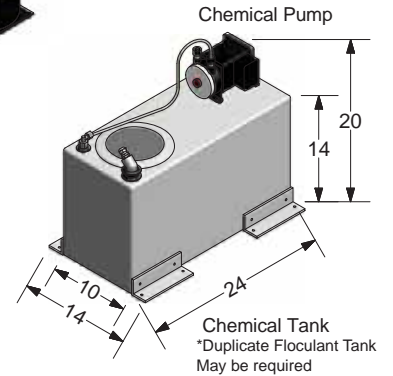
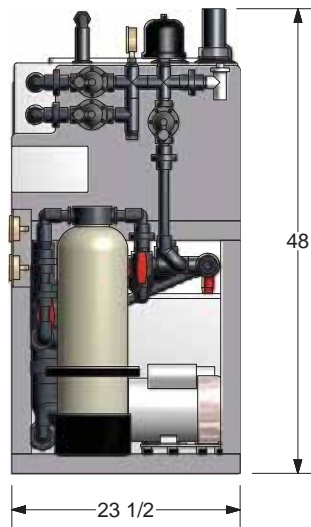
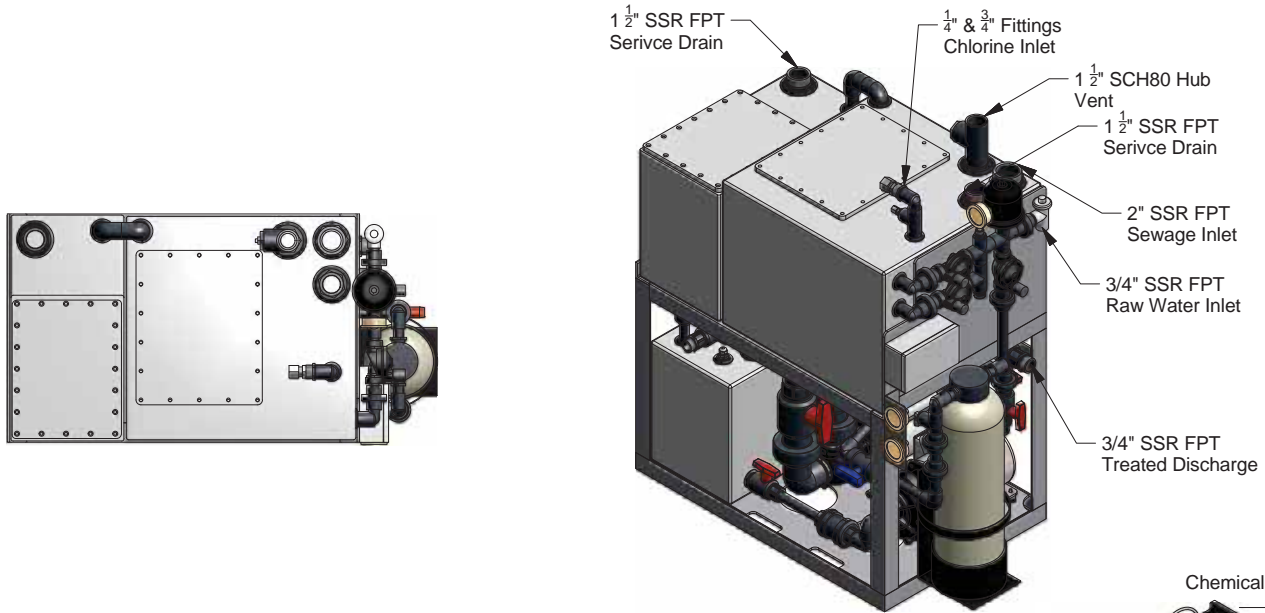

Rated Capacity:
Hydraulic Load: 2000 Gallons per day
Organic load: 7.3 Kg/day

Dry Weight: 300 Lbs.
Max Operational Weight: 1000 Lbs.

Sewage Inlet: 2" SSR FPT (Stainless Steel Reinforced Female Pipe Thread)

Discharge: 3/4" SSR FPT
Vents: 1.5" SSR FPT, 1.5" SCH80 Hub
Raw Water Inlet: 3/4" SSR FPT

Construction Method: 1/4" 5083 Aluminum and HDPE
Coating: 2 Part Urethane
Maximum Test Pressure: 5psi (207mbar)
Operating temperature: 32°F-120°F (0°C-49°C)
Max Pitch/Roll Angle: 22.5° Maximum

Overall Dimensions:
Length: 44" (11753mm)
Width: 23.5" (597mm)
Height: 48" (1219mm)

System Power

Input Power: 110-120VAC, 1Ø, 60hz
220-240VAC, 1Ø, 50/60hz
208-230VAC, 3Ø, 60hz
380-415VAC, 3Ø, 50hz
460-480VAC, 3Ø, 60hz

TW-HMX-6004LP

Standard Specifications

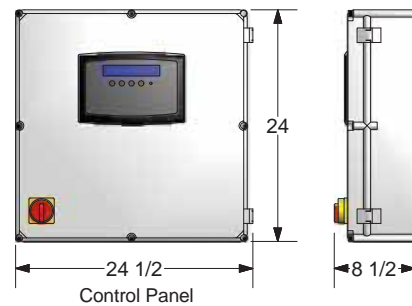
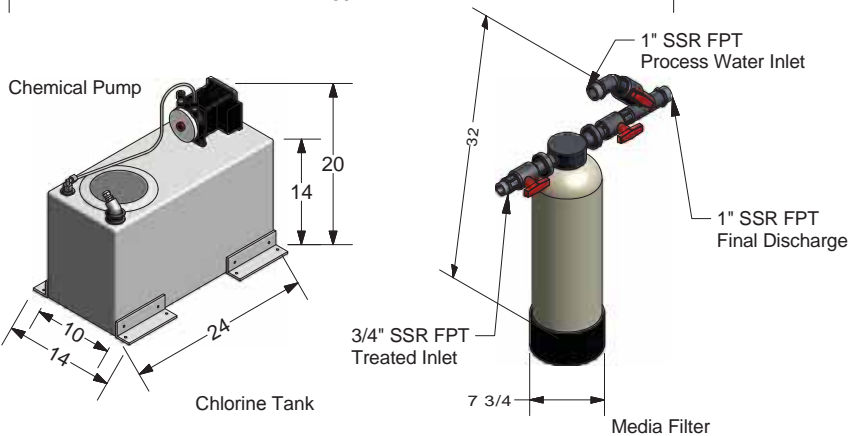
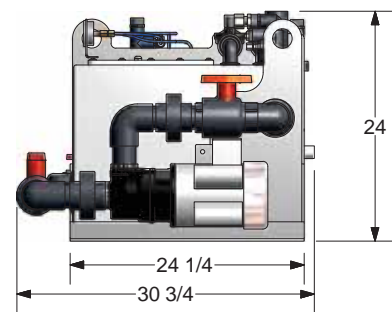
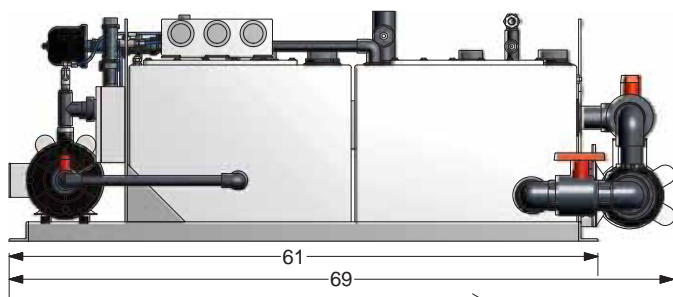
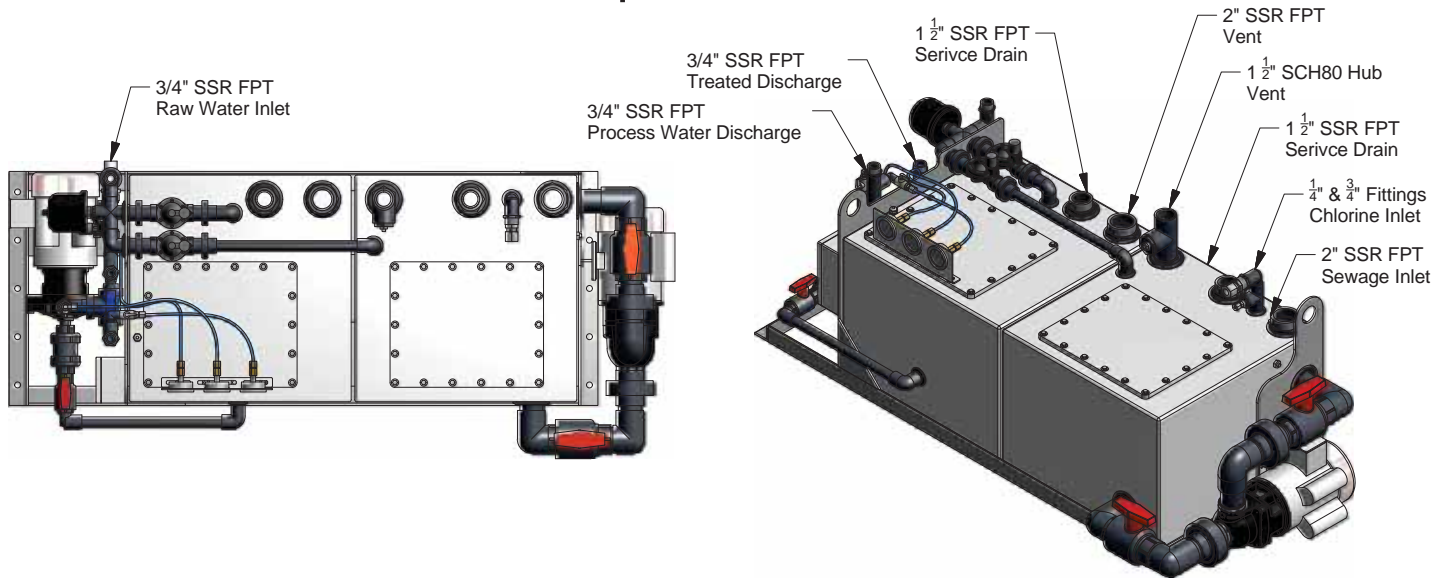

System Power

Input Power:	110-120VAC, 1Ø, 60hz
	220-240VAC, 1Ø, 50/60hz
	208-230VAC, 3Ø, 60hz
	380-415VAC, 3Ø, 50hz
	460-480VAC, 3Ø, 60hz

Rated Capacity:	2000 Gallons per day
Hydraulic Load:	7.3 Kg/day
Organic load:	

Overall Dimensions:	
Length:	69" (1753mm)
Width:	30.75" (781mm)
Height:	24" (610mm)

Dry Weight:	300 Lbs.
Max Operational Weight:	1000 Lbs.

Sewage Inlet:	2" SSR FPT (Stainless Steel Reinforced Female Pipe Thread)
---------------	--

Discharge:	3/4" SSR FPT
Vents:	1.5" SSR FPT, 1.5" SCH80 Hub
Raw Water Inlet:	3/4" SSR FPT

Construction Method:	1/4" 5083 Aluminum and HDPE
Coating:	2 Part Urethane
Maximum Test Pressure:	5psi (207mbar)
Operating temperature:	32°F-120°F (0°C-49°C)
Max Pitch/Roll Angle:	22.5° Maximum

TW-HMX-6204 Standard Specifications

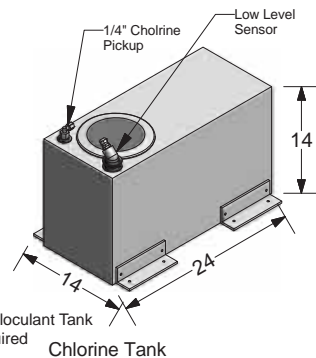
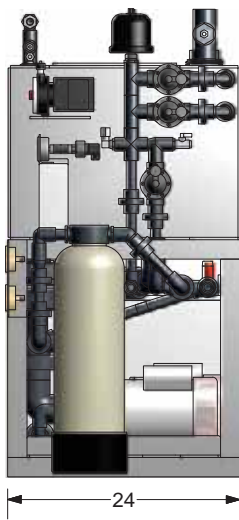
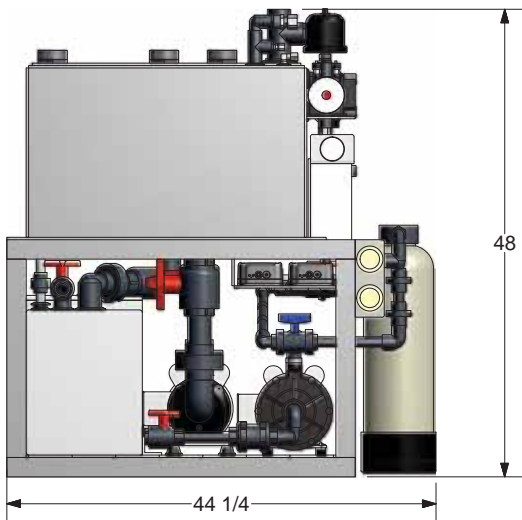
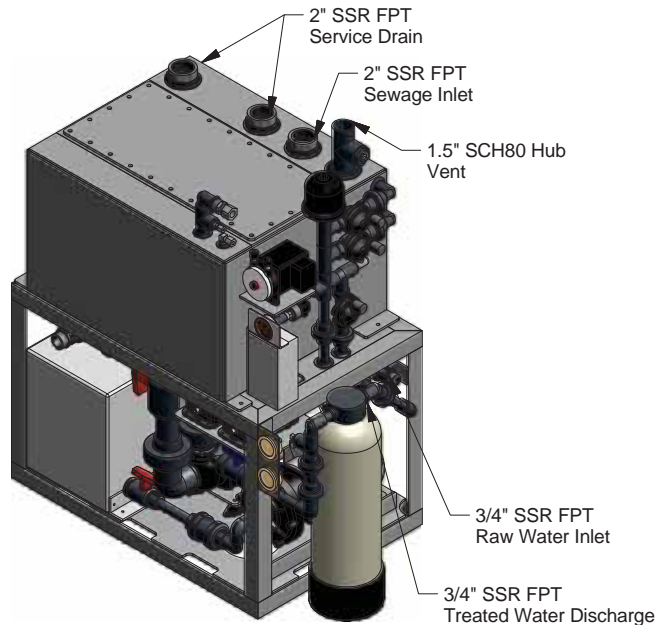
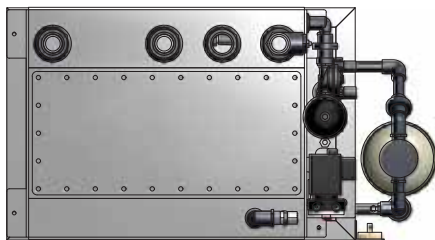

Rated Capacity:
Hydraulic Load: 2000 Gallons per day
Organic load: 7.3 Kg/day

Dry Weight: 900 Lbs.
Max Operational Weight: 1650 Lbs.

Sewage Inlets: 2" SSR FPT (Stainless Steel Reinforced Female Pipe Thread)

Discharge: 3/4" SSR FPT
Vents: 2" SSR FPT / 1.5" SCH80 Hub
Raw Water Inlet: 3/4" SSR FPT

Construction Method: 1/4" A36 Steel and HDPE
Coating: Phenicon HS Epoxy
Maximum Test Pressure: 7 feet of Water (3psi) (207mbar)
Operating temperatures: 32°F-120°F (0°C-49°C)
Max Pitch/Roll Angle: 22.5° Maximum

*Also Available
in 1/4" 5086
Aluminum

Overall Dimensions:
Length: 24" (610mm)
Width: 44.25" (1124mm)
Height: 48" (1219mm)

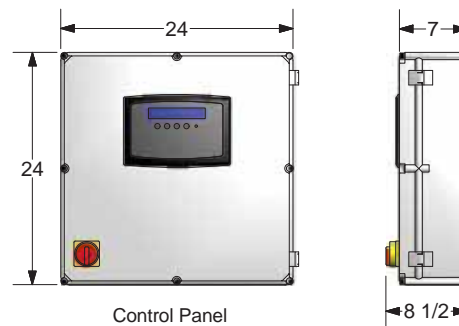

System Power

Input Power: 110-120VAC, 1Ø, 60hz
220-240VAC, 1Ø, 50/60hz
208-230VAC, 3Ø, 60hz
380-415VAC, 3Ø, 50hz
460-480VAC, 3Ø, 60hz

TW-HMX-6204LP Standard Specifications

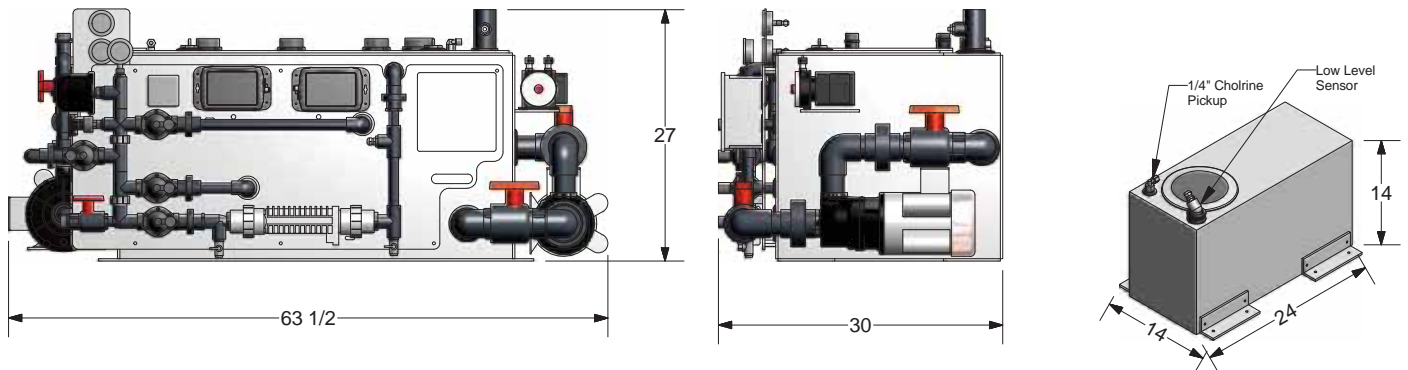
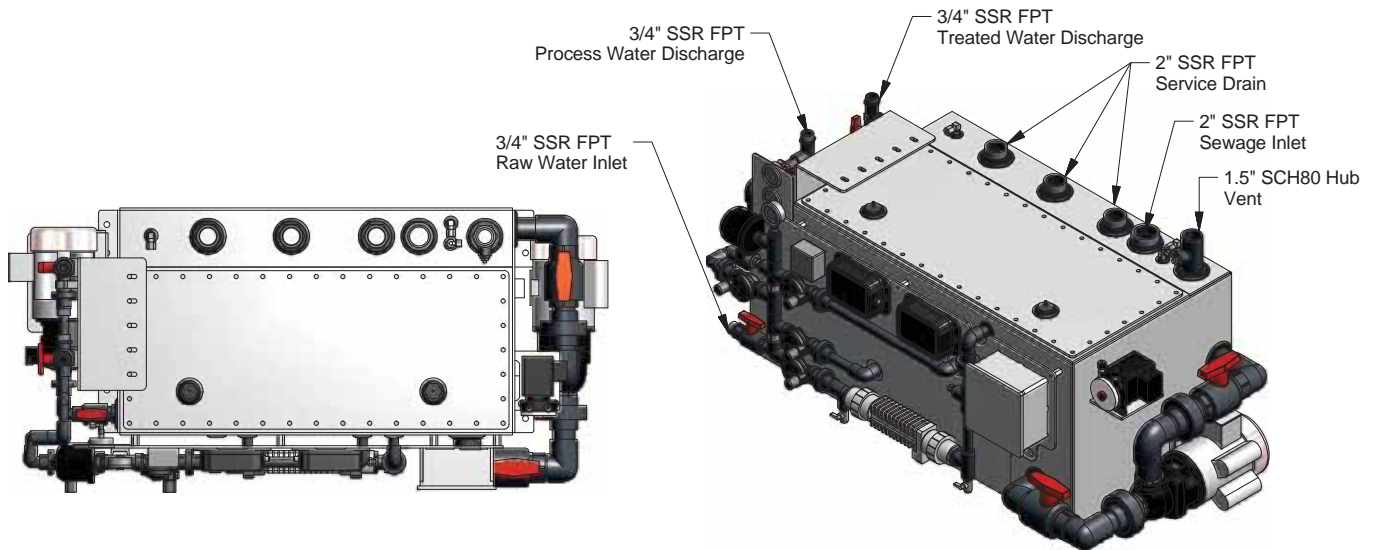

Rated Capacity:
Hydraulic Load: 2000 Gallons per day
Organic load: 7.3 Kg/day

Dry Weight: 900 Lbs.
Max Operational Weight: 1650 Lbs.

Sewage Inlets: 2" SSR FPT (Stainless Steel Reinforced Female Pipe Thread)

Discharge: 3/4" SSR FPT
Vents: 2" SSR FPT / 1.5" SCH80 Hub
Raw Water Inlet: 3/4" SSR FPT

Construction Method: 1/4" A36 Steel *Also Available in 1/4" Aluminum
Coating: Phenicon HS Epoxy
Maximum Test Pressure: 7 feet of Water (3psi) (207mbar)
Operating temperatures: 32°F-120°F (0°C-49°C)
Max Pitch/Roll Angle: 15° Maximum

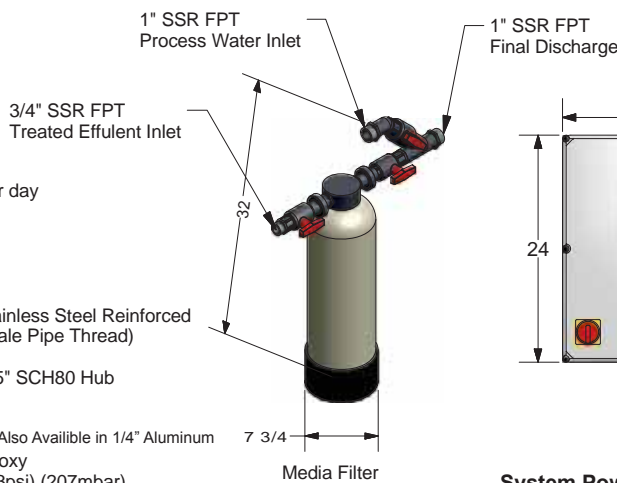

Overall Dimensions:
Length: 30" (762mm)
Width: 63.5" (1613mm)
Height: 27" (686mm)

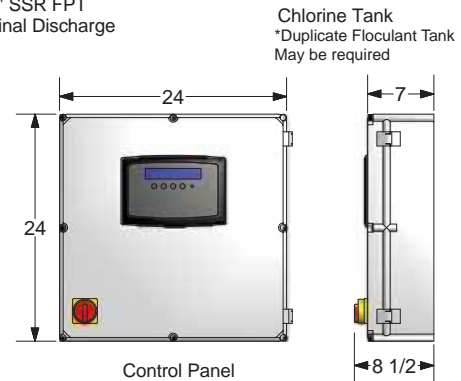

System Power

Input Power: 110-120VAC, 1Ø, 60hz
220-240VAC, 1Ø, 50/60hz
208-230VAC, 3Ø, 60hz
380-415VAC, 3Ø, 50hz
460-480VAC, 3Ø, 60hz

TW-HMX-7005

Standard Specifications

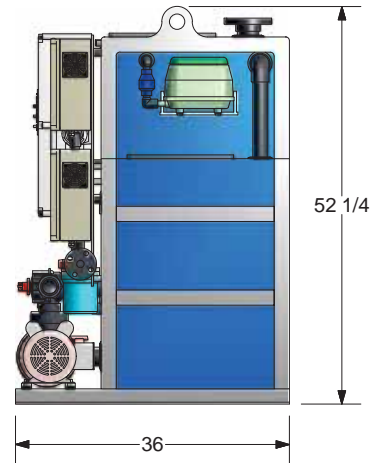
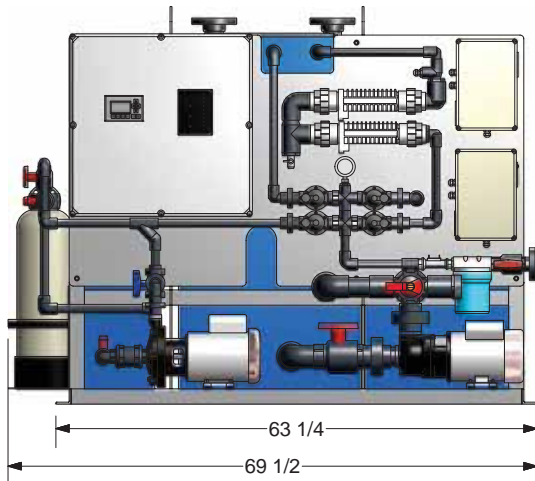
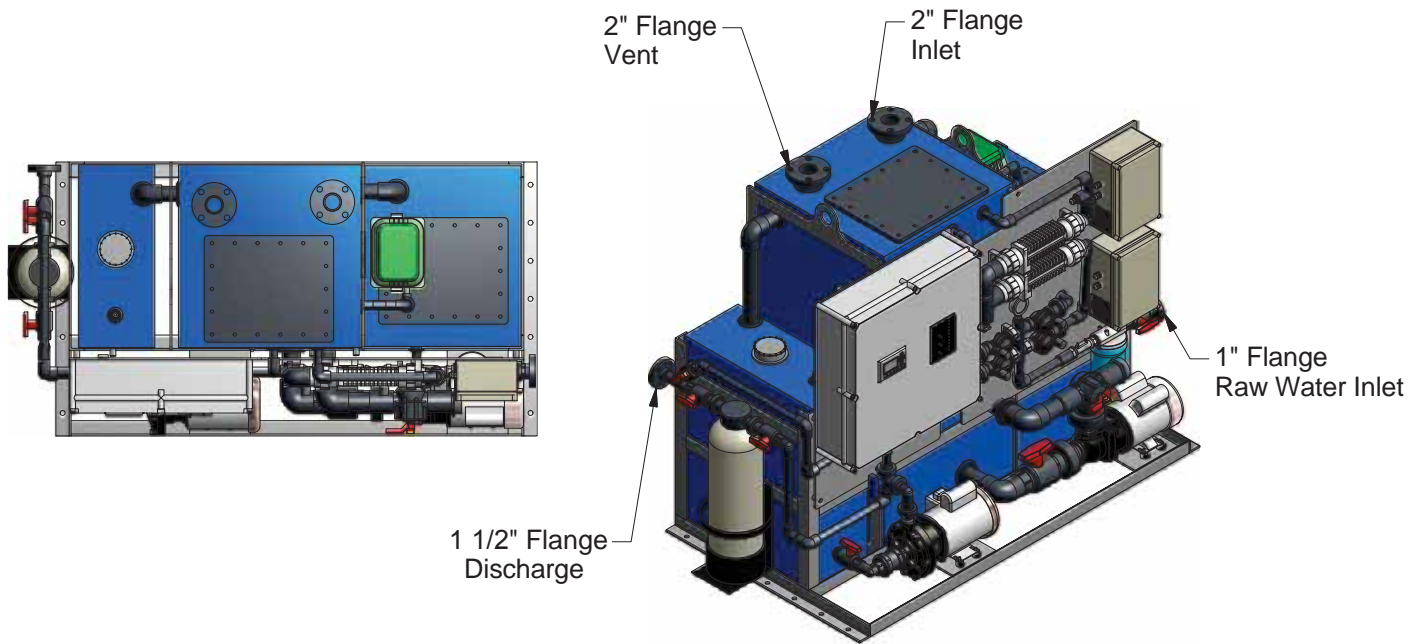

Rated Capacity:
 Hydraulic Load: 5000 Gallons per day
 Organic load: 18.1 Kg/day

Dry Weight: 600 Lbs.
 Max Operational Weight: 1500 Lbs.

Sewage Inlets: 2" Flange
 Discharge: 1" Flange
 Vents: 2" Flange
 Raw Water Inlet: 1" Flange

Construction Method: 1/4" 5083 Aluminum, HDPE
 Coating: 2 Part Urethane
 Maximum Test Pressure: 7 ft. Water Column (207mbar)
 Operating temperatures: 32°F-120°F (0°C-49°C)
 Max Pitch/Roll Angle: 22.5° Maximum

Overall Dimensions:
 Length: 69.5" (1765mm)
 Width: 36" (914mm)
 Height: 52.25" (1327mm)

System Power

Input Power: 110-120VAC, 1Ø, 60hz
 220-240VAC, 1Ø, 50/60hz
 208-230VAC, 3Ø, 60hz
 380-415VAC, 3Ø, 50hz
 460-480VAC, 3Ø, 60hz

TW-HMX-7205 Standard Specifications

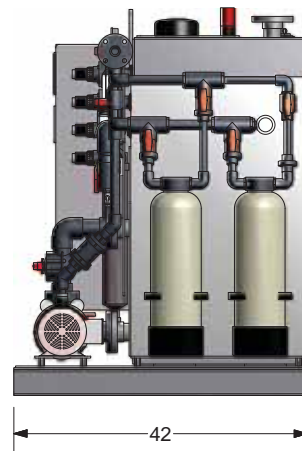
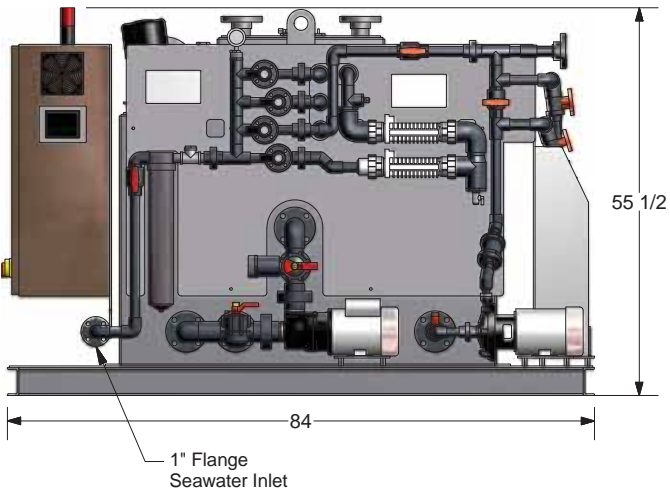
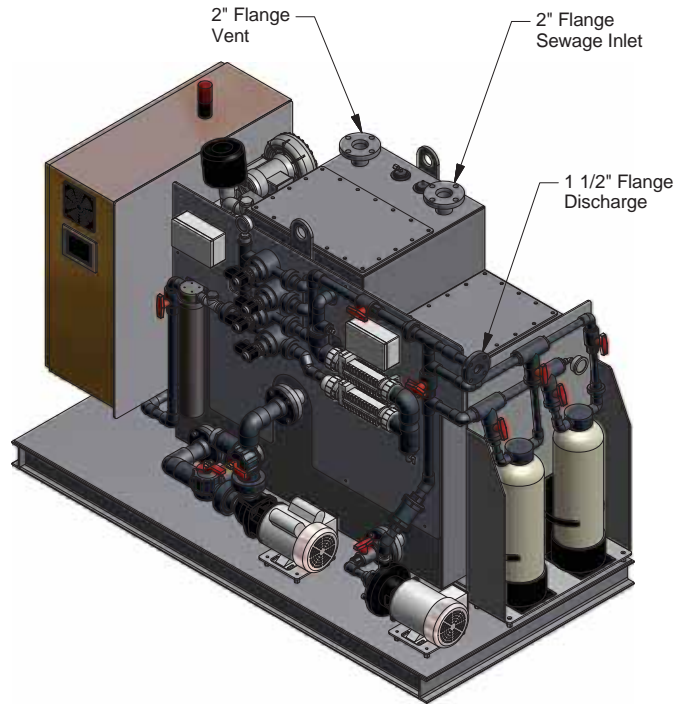
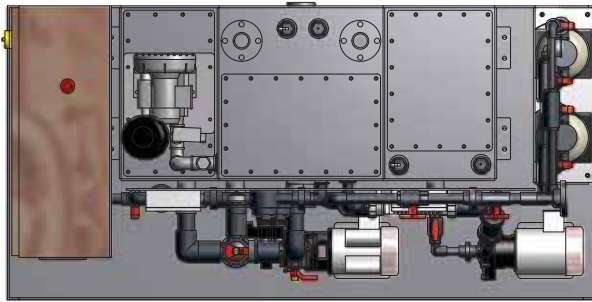

Rated Capacity:
Hydraulic Load: 5000 Gallons per day
Organic load: 18.1 Kg/day

Overall Dimensions:
Length: 84" (2134mm)
Width: 42" (1067mm)
Height: 55.5" (1410mm)

System Power

Input Power: 220-240VAC, 1Ø, 50/60hz
208-230VAC, 3Ø, 60hz
380-415VAC, 3Ø, 50hz
460-480VAC, 3Ø, 60hz

Dry Weight: 2700 Lbs.
Max Operational Weight: 3900 Lbs.

Sewage Inlet: 2" Flange
Discharge: 1.5" Flange
Vent: 2" Flange
Seawater Inlet: 1" Flange

Construction Method: 1/4" A36 Steel *Also Available in 1/4" 5086 Aluminum
Coating: Phenicon HS Flake Filled/Epoxy with 2 Part Urethane
Maximum Test Pressure: 5psi (207mbar)
Operating temperature: 32°F-120°F (0°C-49°C)
Max Pitch/Roll Angle: 22.5° Maximum



Touch Screen Control

TW-HMX-8203

Standard Specifications

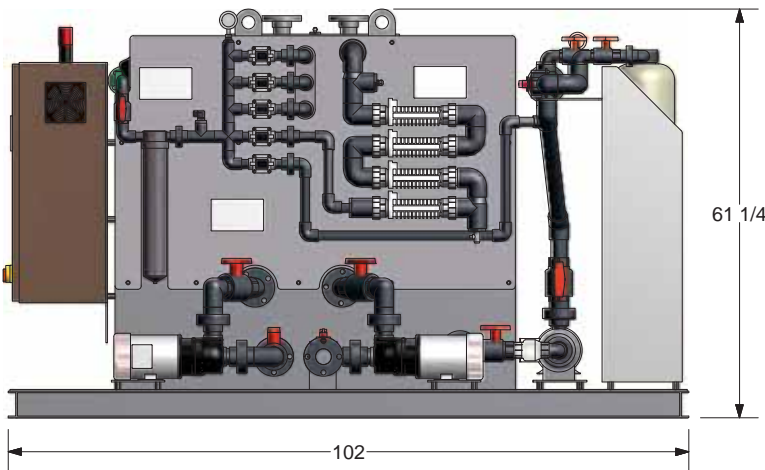
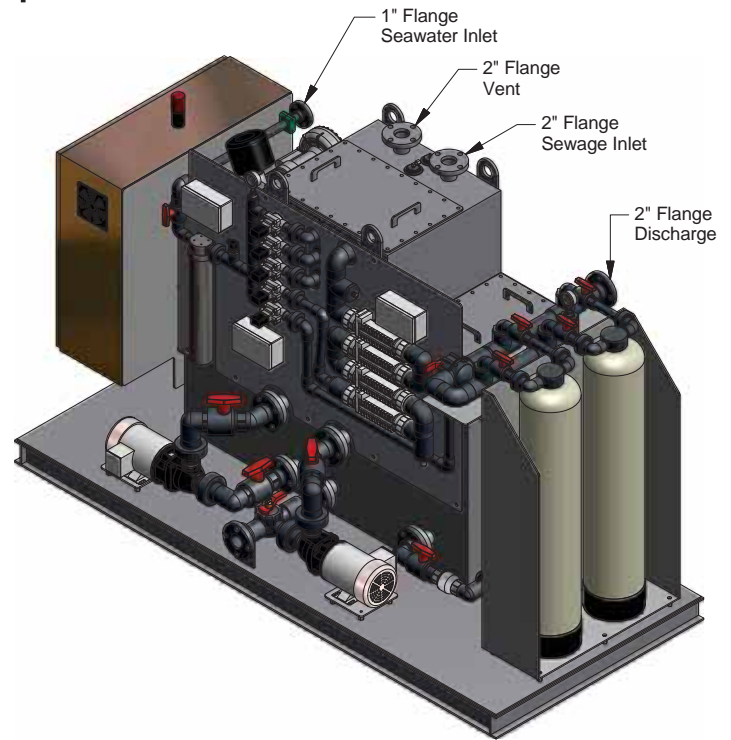
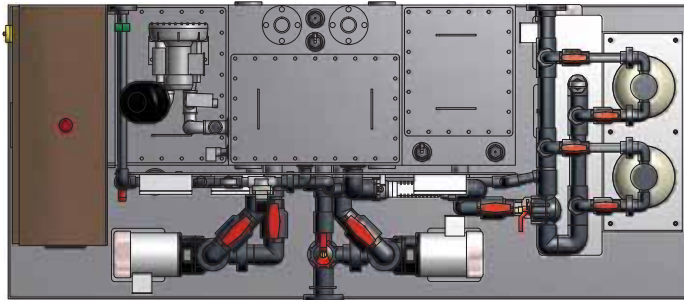

Rated Capacity:
 Hydraulic Load: 10,000 Gallons per day
 Organic load: 36.3 Kg/day

Overall Dimensions:
 Length: 102" (2591mm)
 Width: 44" (1118mm)
 Height: 61.25" (1556mm)

System Power

Input Power:
 220-240VAC, 1Ø, 50/60hz
 208-230VAC, 3Ø, 60hz
 380-415VAC, 3Ø, 50hz
 460-480VAC, 3Ø, 60hz

Dry Weight: 3900 Lbs.
Max Operational Weight: 11900 Lbs.

Sewage Inlet: 2" Flange
Discharge: 2" Flange
Vent: 2" Flange
Seawater Inlet: 1" Flange

Construction Method: 1/4" A36 Steel*Also Available in 1/4" 5086 Aluminum
Coating: Phenicon HS Flake Filled/Epoxy with 2 Part Ureth
Maximum Test Pressure: 5psi (207mbar)
Operating temperature: 32°F-120°F (0°C-49°C)
Max Pitch/Roll Angle: 22.5° Maximum



Touch Screen Control

TW-HMX-8205 Standard Specifications

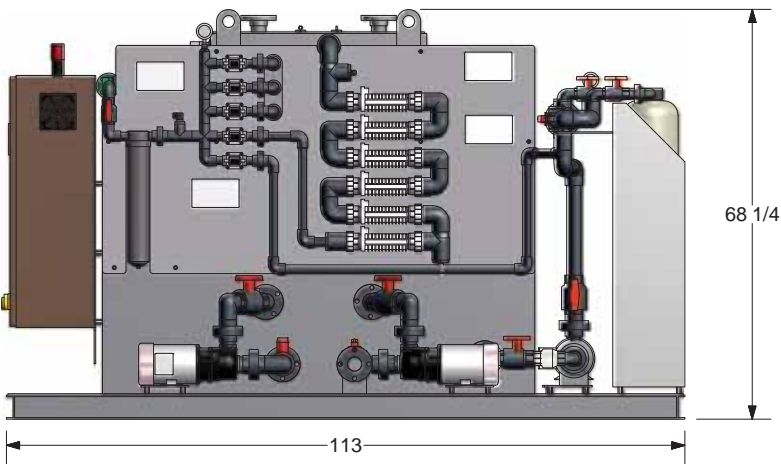
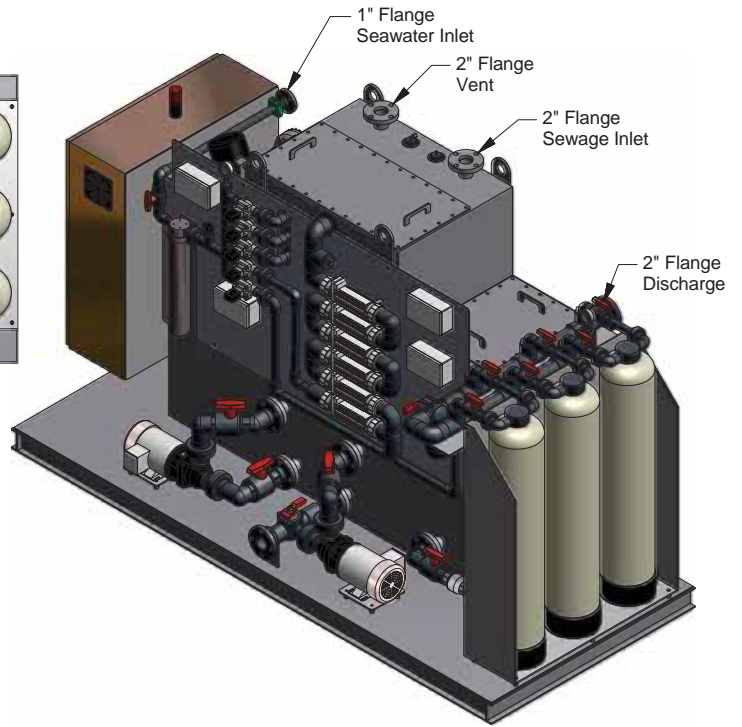
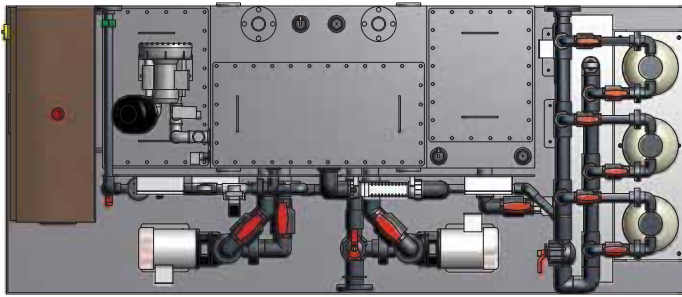

Rated Capacity:
Hydraulic Load: 15,000 Gallons per day
Organic load: 54.4 Kg/day

Overall Dimensions:
Length: 113" (2870mm)
Width: 48" (1178mm)
Height: 68.25" (1734mm)

System Power

Input Power: 208-230VAC, 3Ø, 60hz
380-415VAC, 3Ø, 50hz
460-480VAC, 3Ø, 60hz

Dry Weight: 4200 Lbs.
Max Operational Weight: 14600 Lbs.

Sewage Inlet: 2" Flange
Discharge: 2" Flange
Vent: 2" Flange
Seawater Inlet: 1" Flange

Construction Method: 1/4" A36 Steel *Also Available in 1/4" 5086 Aluminum
Coating: Phenicon HS Flake Filled/Epoxy with 2 Part Ureth;
Maximum Test Pressure: 5psi (207mbar)
Operating temperature: 32°F-120°F (0°C-49°C)
Max Pitch/Roll Angle: 22.5° Maximum



Touch Screen Control

TW-HMX-9202 Standard Specifications

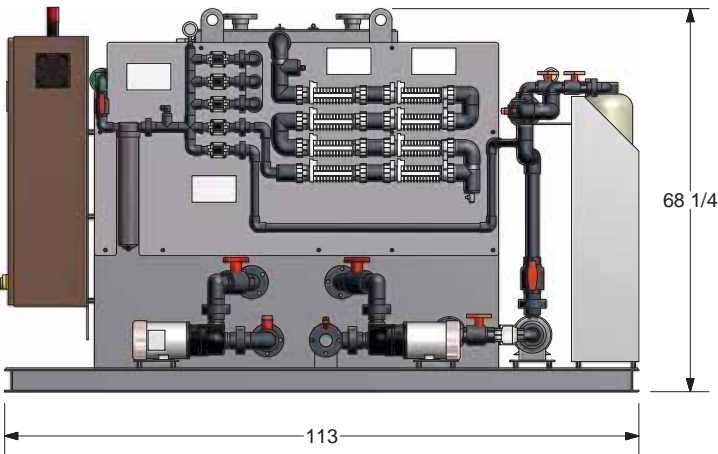
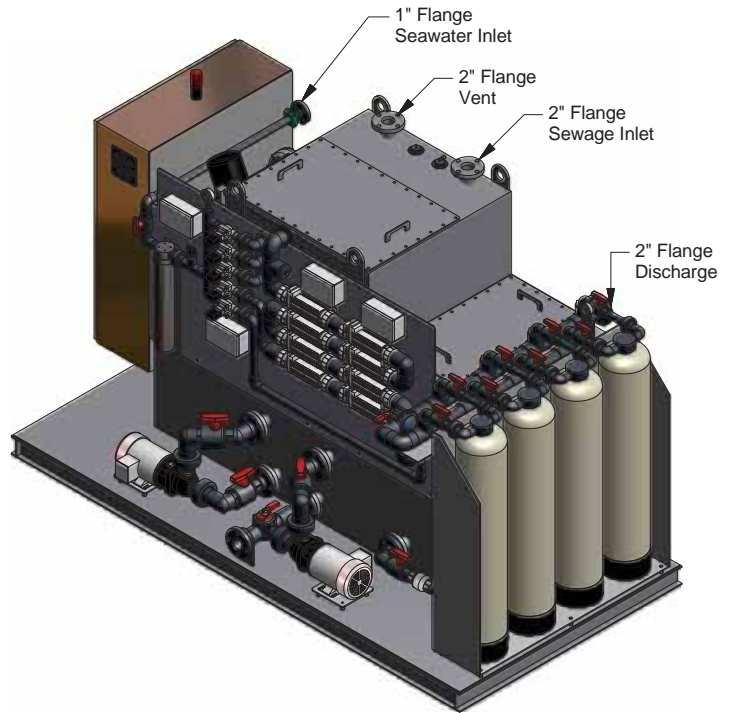
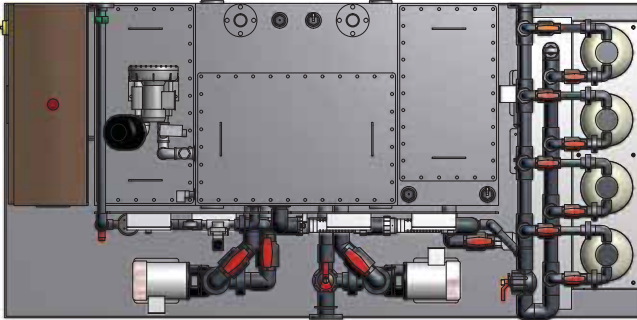

Rated Capacity:
Hydraulic Load: 20,000 Gallons per day
Organic load: 72.6 Kg/day

Overall Dimensions:
Length: 113" (2870mm)
Width: 56" (1422mm)
Height: 68.25" (1734mm)

System Power

Input Power: 208-230VAC, 3Ø, 60hz
380-415VAC, 3Ø, 50hz
460-480VAC, 3Ø, 60hz

Dry Weight: 4700 Lbs.
Max Operational Weight: 15000 Lbs.

Sewage Inlet: 2" Flange
Discharge: 2" Flange
Vent: 2" Flange
Seawater Inlet: 1" Flange

Construction Method: 1/4" A36 Steel*Also Available in 1/4" 5086 Aluminum
Coating: Phenicon HS Flake Filled/Epoxy with 2 Part Urethane
Maximum Test Pressure: 5psi (207mbar)
Operating temperature: 32°F-120°F (0°C-49°C)
Max Pitch/Roll Angle: 22.5° Maximum



Touch Screen Control

Built For Your Needs

Specialized Sewage Treatment Plants

Headhunter's Tidal Wave HMX Sewage treatment systems are customized for the unique requirements of various applications. Offshore installations often dictate that equipment is prepared for IEC or NEC hazardous environments. Installation aboard a series of high speed military vessels required that a modular approach to construction and operation be developed. Some examples of our solutions are shown on the pictures below.



Class 1 Div 1
Skid mounted Sewage Treatment Plant Package
for Hazardous Area Environment

Built for Zone 2 hazardous environment CE approved
Skid mounted Sewage Treatment Plant package
for offshore platform



From modular on site assembly due to space
requirements on rigs to staged and redundant
sewage treatment plants for specialized military
applications



Headhunter's rugged
custom treatment system
control panels makes system
integration simple
and reliable.



Modular 300 gallons per day bilge shaped system



Skid mounted for Military Vessel TW-HMX Tidal Wave Sewage
Treatment Plant Certified to IMO MEPC.159(55)



Skid mounted 300 gallon per day system with integrated duplex
pump system, and control panel

Turn Ideas Into Reality

Whether it's a space-saving modular unit designed for the bilge of a large megayacht, or a skid-mounted turn key package complete with lift stations, and dual language control panels for a foreign navy, the Headhunter team is ready to take on the challenge.



Custom Design

Headhunter's team of engineers, fabricators, and wastewater specialists work together to take an idea from rough sketch to a 3D CAD model. This unique pool of talent, technology, and creativity allow Headhunter to provide not only superior customer service, but also innovative sewage treatment system solutions in a broad variety of configurations and materials.



Quality In-house Fabrication & Coating

Many competitors subcontract their fabrication to outside companies. As a result, control over quality and delivery is compromised. At Headhunter, our own in house, highly skilled fabrication team bring to life custom built systems in aluminum, steel, and stainless while maintaining a commitment to our customers for quality and timely delivery.



Headhunter application engineers are available to travel all over the world to assist customers before, during, and after system installation.



In order to maintain the highest level of quality and timely delivery, all Tidal Wave Treatment Plants are fabricated inhouse by Headhunter's own motivated team of certified welders, painters, pipe fitters, and electricians.



TW-HMX-6001LP with Holding Tank Standard Specifications

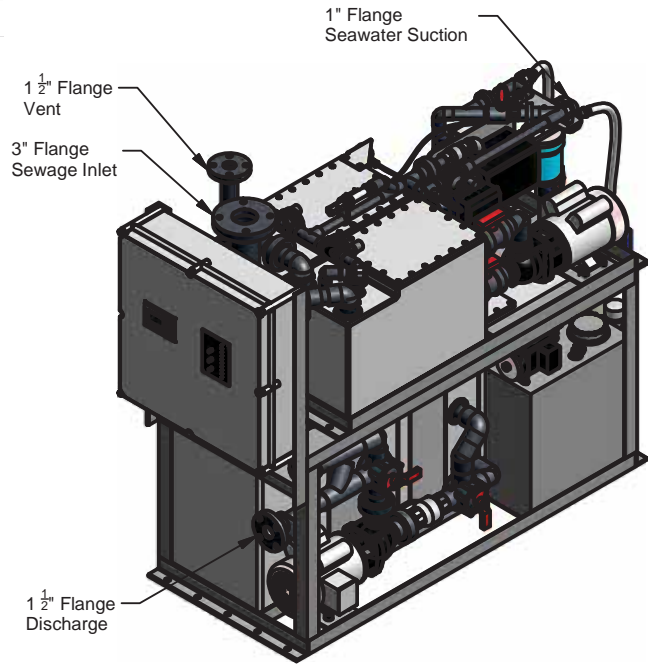
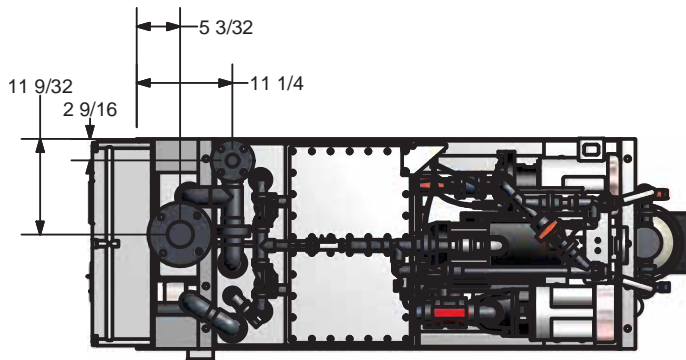

All Units In Inches

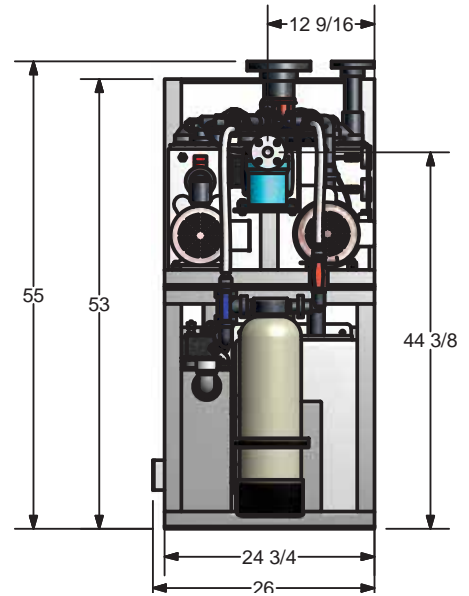
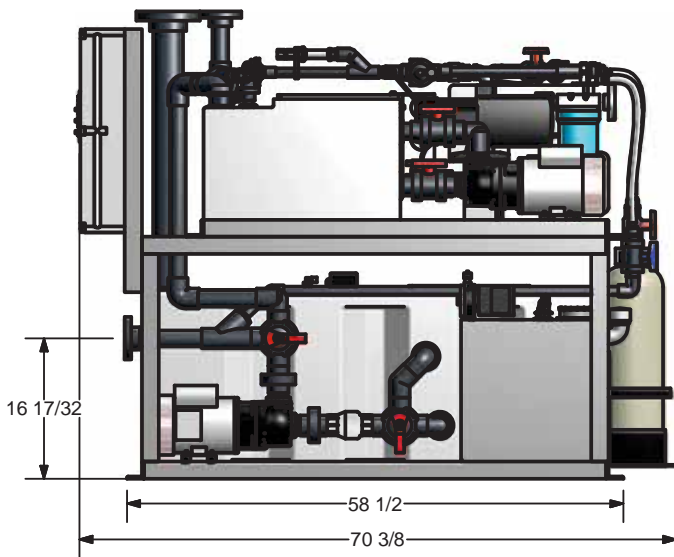

Rated Capacity: 600 Gallons per day (2.25 m³)
 Hydraulic Load: 2.2 Kg/day
 Organic load:

Dry Weight: 300 Lbs. (136 Kg)
 Max Operational Weight: 1150 Lbs. (522 Kg)

Sewage Inlet: 3" Flange 150 psi ANSI B16.5
 Discharge: 1 1/2" Flange 150 psi ANSI B16.5
 Vent: 1 1/2" Flange 150 psi ANSI B16.5
 Seawater suction: 1" Flange 150 psi ANSI B16.5

Construction Method: 1/4" 5083 Aluminum and HDPE
 Piping (CPVC) ASTM F 439
 Coating: 2 part Urethane
 Maximum Test Pressure: 5psi (207mbar)
 Operating Pressure: Atmospheric
 Operating temperature: 32°F-120°F (0°C-49°C)
 Max Pitch/Roll Angle: 22.5° Maximum

Overall Dimensions:
 Length: 70.375" (1788mm)
 Width: 26" (663mm)
 Height: 55" (1400mm)

System Power
 Input Power:

110-120VAC, 1Ø, 60hz
 220-240VAC, 1Ø, 50/60hz
 208-230VAC, 3Ø, 60hz
 380-415VAC, 3Ø, 50hz
 460-480VAC, 3Ø, 60hz

TW-HMX-6204LP with Holding Tank Standard Specifications

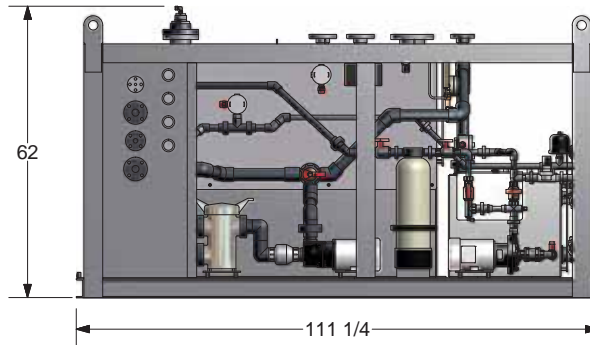
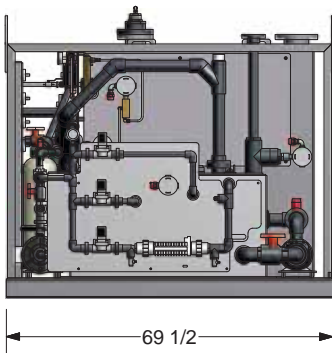
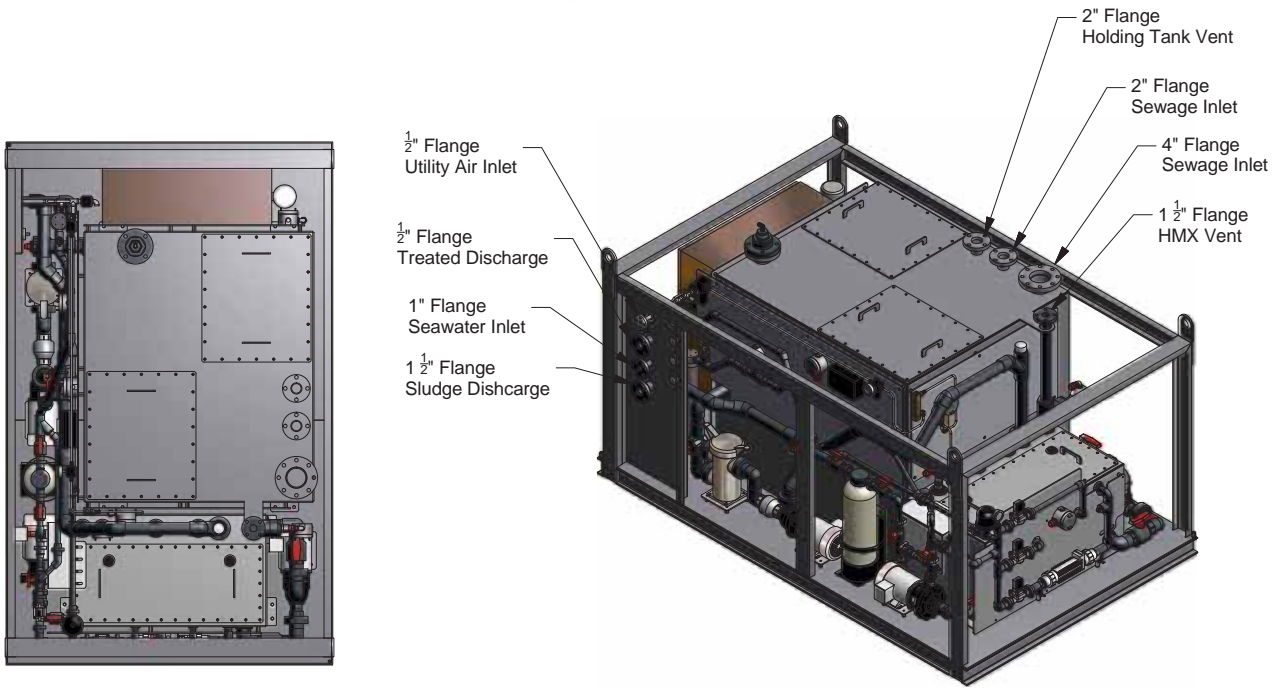

Rated Capacity:
Hydraulic Load: 2000 Gallons per day
Organic load: 7.3 Kg/day

Dry Weight: 4400 Lbs.
Max Operational Weight: 7100 Lbs.

Sewage Inlets: 4" Flange
2" Flange
Discharge: 1 1/2" Flange
Vents: 2" Flange
1 1/2" Flange
Seawater Inlet: 1" Flange
Utility Air Inlet: 1/2" Flange

Construction Method: 1/4" A36 Steel and HDPE *Also Available in 1/4" 5086 Aluminum
Coating: Phenicon HS Epoxy
Maximum Test Pressure: 7 feet of Water (3psi) (207mbar)
Operating temperatures: 32°F-120°F (0°C-49°C)
Max Pitch/Roll Angle: 22.5° Maximum

Overall Dimensions:
Length: 111.25" (2826mm)
Width: 69.5" (1765mm)
Height: 62" (1576mm)

System Power
Input Power:

208-230VAC, 3Ø, 60hz
380-415VAC, 3Ø, 50hz
460-480VAC, 3Ø, 60hz

Type II MSD Physical Chemical Systems



- Low maintenance
- Odor Free
- USCG certified
- Includes effluent discharge pump for overboard discharge of treated waste
- Easy/automatic operation
- Tough corrosion resistant materials
- Lightweight units
- NRTL Listed construction available for Hazardous Area installation

TIDALWAVE HMX® are U.S. Coast Guard certified Type II Marine Sanitation Devices (MSDs) in accordance with 33CFR Part 159. These systems are recommended for US Flagged vessels over 65 feet long. Standard models are available to treat up to 50,000 US Gallons per day (189 cubic meters per day). These systems provide automated state of the art processing of onboard sewage. Designed for quick starts and stops with the push of a button, the TIDALWAVE HMX® system uses chemical oxidation, hydro-maceration and patented cross-flow separation techniques to thoroughly destroy influent biomass. The optional AutoClor® Electrolytic chlorine generator system generates sodium hypochlorite on location from seawater or brine, thus eliminating consumables during operation. The four-stage treatment system provides trouble free treatment of black and gray water with a sterile effluent for disposal. These systems are provided in marine grade aluminum or steel construction with a high solids loaded epoxy coating for superior corrosion protection.



Listing# E212282



HMX-500 Series

Designed for up to 48 people and hydraulic loads up to 2,000 gallons per day these systems are offered in two versions. The 500 Series frame mounted version offers a reduced footprint for installations where engine room floor space is at a premium. With the chlorine solution tank, the circulating pump and the effluent sump stacked underneath the first processing chambers, a compact and serviceable system can easily be installed. The control panel is included and mounted separately. Input voltage is typically single phase 115 volt or 220 volt, 50/60 Hz. Pressurized sea water is required for all HMX systems and typically supplied with our Stingray pump on these

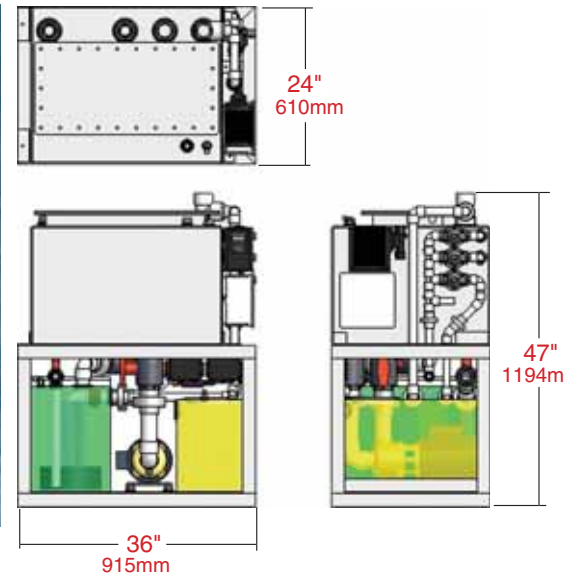

HMX-500 Low Profile Series



With the same performance characteristics as the stacked HMX, these low profile models are designed to slip in to tight spaces with the optional AutoClor® Electrolytic chlorine generator system mounted onboard the tank. Remote mounted accessories include the system control panel and chlorine solution tank.

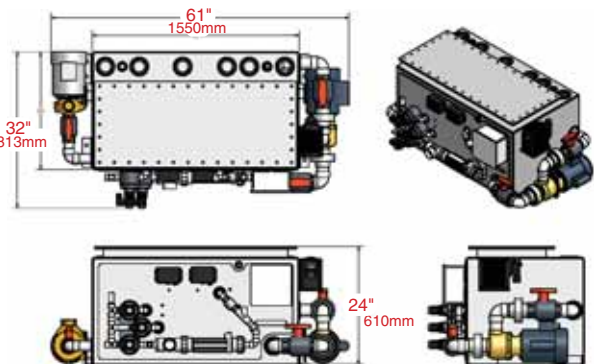

MODEL	DIMENSION (L-W-H)	SHIP WEIGHT	OP. WEIGHT	POWER (kVA)	HYDRAULIC LOAD Gal (m ³) / day	BOD LOAD kg (lbs) / day
TW-HMX-5*1	36"x 24"x 47"	325 lbs.	835 lbs.	5.28	600 (2.27)	1.4 (3.0)
TW-HMX-5*2	36"x 24"x 47"	325 lbs.	835 lbs.	5.28	1,200 (4.54)	2.8 (6.0)
TW-HMX-5*3	36"x 24"x 47"	325 lbs.	835 lbs.	5.28	1,800 (6.81)	4.1 (9.0)
TW-HMX-5*4	36"x 24"x 47"	325 lbs.	835 lbs.	5.28	2,000 (7.57)	5.5 (12.0)
TW-HMX-5*1LP	61"x 32"x 24"	325 lbs.	835 lbs.	5.28	600 (2.27)	1.4 (3.0)
TW-HMX-5*2LP	61"x 32"x 24"	325 lbs.	835 lbs.	5.28	1,200 (4.54)	2.8 (6.0)
TW-HMX-5*3LP	61"x 32"x 24"	325 lbs.	835 lbs.	5.28	1,800 (6.81)	4.1 (9.0)
TW-HMX-5*4LP	61"x 32"x 24"	325 lbs.	835 lbs.	5.28	2,000 (7.57)	5.5 (12.0)

* Substitute, 1- Aluminum or a 2-Steel, for type of construction

HMX Treatment Systems

HMX-2000 through 5000 Series

With capacities up to 50,000 gallons per day these are the biggest marine sewage treatment systems you'll find anywhere. The patented cross flow filtration technique, treats large hydraulic loads in a small space. All Tidal Wave HMX systems can be programmed once installed to meet changing performance criteria, and varying hydraulic or organic loading. These are the perfect systems for commercial applications where space is at a premium, and performance under all situations is expected. Type test approved to USCG and IMO performance standards these systems can easily be configured to exceed the most stringent new codes.



TW-HMX-3202 Class I Div II built for offshore platform

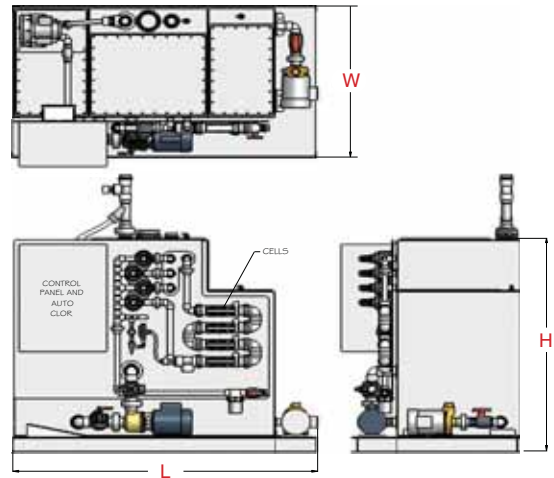

MODEL	DIMENSION (L-W-H)	SHIP WEIGHT	OP. WEIGHT	POWER (kVA)	HYDRAULIC LOAD Gal (m ³) / day	BOD LOAD kg (lbs) / day
TW-HMX-2*02	60"x 38"x 45"	500 lbs.	1,600 lbs.	5.28	3,000 (11.4)	6.8 (15)
TW-HMX-2*03	60"x 38"x 45"	500 lbs.	1,600 lbs.	6.20	3,600 (13.6)	8.2 (18)
TW-HMX-2*04	60"x 38"x 45"	500 lbs.	1,600 lbs.	6.20	4,200 (15.9)	9.5 (21)
TW-HMX-2*05	60"x 38"x 45"	500 lbs.	1,600 lbs.	6.20	5,000 (18.9)	11 (24)
TW-HMX-3*02	74"x 42"x 58"	635 lbs.	6,250 lbs.	7.35	8,000 (30.3)	18 (40)
TW-HMX-3*03	74"x 42"x 58"	635 lbs.	6,250 lbs.	7.35	10,000 (37.9)	23 (50)
TW-HMX-3*04	74"x 42"x 58"	635 lbs.	6,250 lbs.	7.35	12,000 (45.4)	27 (60)
TW-HMX-4*02	74"x 43"x 68"	725 lbs.	9,575 lbs.	8.50	15,000 (56.8)	34.0 (75)
TW-HMX-4*03	74"x 43"x 68"	725 lbs.	9,575 lbs.	8.50	20,000 (75.7)	45.3 (100)
TW-HMX-4*04	74"x 43"x 68"	725 lbs.	9,575 lbs.	15.40	25,000 (94.6)	56.6 (125)
TW-HMX-4*05	74"x 43"x 68"	725 lbs.	9,575 lbs.	15.40	30,000 (113.6)	68.0 (150)
TW-HMX-5*02	80"x 48"x 68"	850 lbs.	11,350 lbs.	15.40	35,000 (132.50)	79.3 (175)
TW-HMX-5*03	80"x 48"x 68"	850 lbs.	11,350 lbs.	15.40	40,000 (151.40)	90.7 (200)
TW-HMX-5*04	80"x 48"x 68"	850 lbs.	11,350 lbs.	18.85	45,000 (170.34)	102.0 (225)
TW-HMX-5*05	80"x 48"x 68"	850 lbs.	11,350 lbs.	21.00	50,000 (189.27)	113.3 (250)

* Substitute, 1- Aluminum or a 2-Steel, for type of construction

HMX Control Panels

Each HMX control panel includes industrial grade switches, contactors, and motor controllers providing complete overload protection and visual system status during operation. Level indication in the primary macerating chamber, and the dechlorination chamber is visually displayed. Equipment status and alarms are displayed via indicator lights, internal LCD display or on-screen icons. A frequent option is the addition of monitors for the ship's on-board waste tank and control of associated sewage transfer pumps to automate the entire collection and treatment process. An upgraded industrial PLC with touch-screen user interface offers automated integration of the AUTO CLOR alarms, and enables prioritizing of several collection tanks onboard so that the treatment capabilities of your Tidal Wave HMX are thoroughly optimized.



MET Listing# E212275



PLC TouchScreen Monitoring & Control



TW-HMX-3203 built for Galapagos cruise ship

Type II MSD Biological Treatment Systems

USCG Certified Type II Marine Sanitation Device



Complete TW-200 Treatment System

Tidal Wave aerobic biological sewage treatment systems are U.S. Coast Guard certified Type II Marine Sanitation Devices (MSD) in accordance with 33CFR Part 159. These systems are recommended for US Flagged vessels over 65 feet long. Standard models are available to treat 50 to 10,000 US gallons per day (0.2 to 38 cubic meters per day). These systems have no moving parts in the treatment chambers that contact sewage. The biological process is simple, reliable, and efficient. The system makes good environmental sense by working with nature to accelerate the normal biological process. With the addition of oxygen, natural occurring bacteria digest solids and a mild disinfectant is added to kill harmful pathogens. The aerobic process ensures reliable odor free operation. All Tidal Wave systems are available constructed with either 3/16 inch A36 steel or 1/4 inch marine grade aluminum, coated with high solids filled epoxy for superior corrosion protection. Custom designs are available to conform to your specific space configuration. Each treatment system includes a blower, a chemical injection pump, and a polyethylene chlorine solution storage tank. Options include electrical a control panel, tablet feeder, treated effluent discharge pump, or sewage transfer pump. See the following pages for application guidance.



- Reliable biological treatment process
- Odor-free
- Easy to operate
- Compact size
- No moving parts contact sewage
- Virtually maintenance-free
- No harsh chemicals
- Custom models available
- Standard sizes 50-10,000 gallons per day
- Tough, corrosion resistant coating
- Optional high-gloss urethane finish

50-300 Gallons Per Day Systems

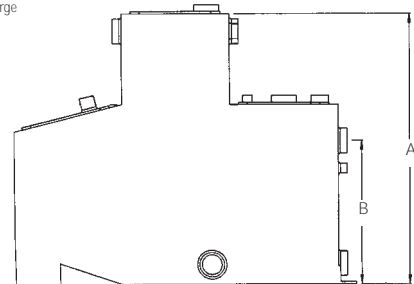
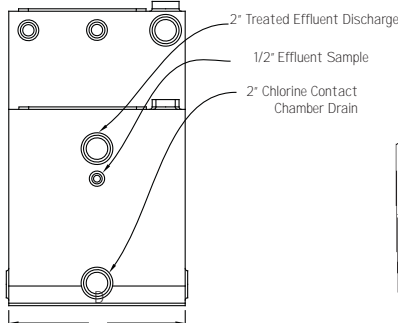
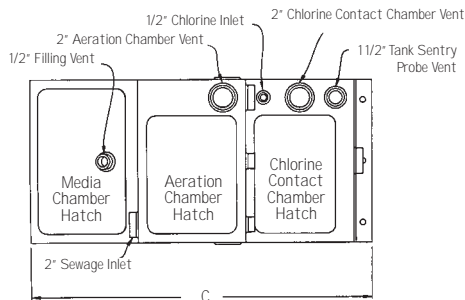

Model Number	Flow rate Gal per day (Ltr per day)	Persons per 24 hrs	Dimensions in inches (mm)				Dry Weight lbs (kg)	Operating Weight lbs (kg)
			Total Height A	Disch. Height B	Total Length C	Tank Width D		
TW-50B	50(189)	10	30(762)	16(406)	38(965)	18(457)	180(82)	580(263)
TW-50LP	50(189)	10	21(533)	12(305)	48(1219)	28(711)	125(57)	700(318)
TW-200B	200(757)	40	36(915)	22(559)	45(1143)	31(787)	350(158)	1258(571)
TW-300B	300(1135)	60	42(1067)	30(762)	45(1143)	31(787)	415(188)	1915(868)



Complete TW-50LP Treatment System

Larger low profile systems available, contact Headhunter for your particular application.

Light Weight Tidal Wave Applications



The standard model in High Density Polyethylene is the TW-50P. Functionally identical to the fabricated systems, they have the added benefit of being molded of lightweight corrosion proof material. Each system includes treatment tank, efficient linear blower, chemical injection pump, and polyethylene disinfectant solution tank. Options include Chinook discharge pump, custom electrical control panels, sewage transfer pumps, or Tank Sentries for monitoring treated effluent level in disinfection chamber.

Model	L (mm)	W (mm)	H (mm)	Dry Weight lbs (kg)	Wet Weight lbs (kg)	AMPS @ 120V	AMPS @ 230V
TW-50B/P	39"(990)	21"(533)	30"(762)	130(58)	515(234)	2.3	1.7
TW-50B/CP	47"(1194)	21"(533)	37"(940)	160(73)	545(247)	9.2	5.2

Tidal Wave Marine Sanitation Device



The Tidal Wave combines proven technology with modern manufacturing techniques to yield a lightweight, reliable, and simple treatment system solution for the rigors of today's commercial offshore environment.

SPECIFICATIONS

- 5083 marine grade aluminum
- A-36 U.S. Steel
- SSPC 5 blast profile 1.5-2.0 mils
- High solids flake filled VOC-compliant epoxy
- Data-Couple used for aluminum to steel bonding
- Auto-Cad Design supplied

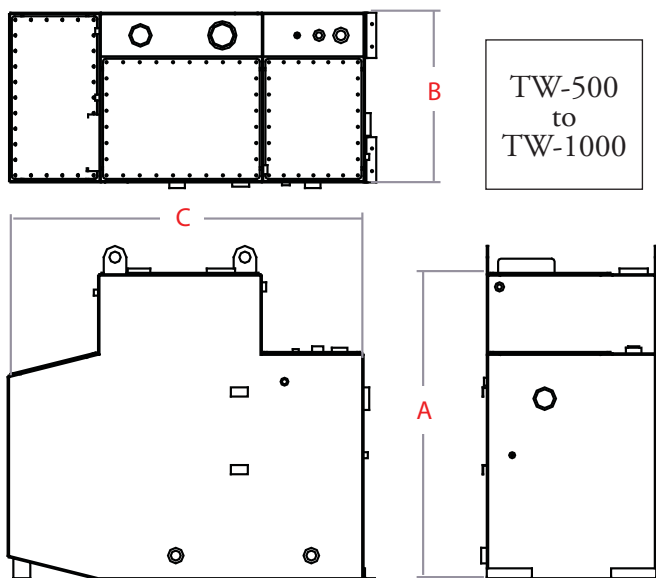

Tidal Wave Treatment Systems can be customized with a variety of options. The TW-5000 model shown is a one-piece unit. It's assembled for easy handling featuring a tablet feeder, explosion proof blower and attached disinfection chamber. One crane lift and this system is installed. Other options include duplex discharge pumps automatically controlled and alternated by the custom electrical control panel.

Model Number	Flow rate Gal per day (L tr per day)	Persons per 24 hrs	Dimensions in inches (mm)			Dry Weight lbs (kg)	Operating Weight lbs (kg)
			Height A	Width B	Length C		
TW-500	500(1892)	100	54(1372)	23(584)	70(1778)	446(201)	3267(1470)
TW-800	800(3028)	160	60(1524)	30(762)	72(1829)	563(253)	3863(1738)
TW-1000	1000(3785)	200	72(1829)	60(1524)	46(1169)	623(280)	4868(2191)
TW-1200	1200(4542)	240	72(1829)	60(1524)	52(1321)	695(318)	5789(2605)
TW-1600	1600(6056)	320	72(1829)	60(1524)	64(1626)	840(378)	7632(3434)
TW-2000	2000(7570)	400	72(1829)	76(1930)	72(1829)	1015(457)	10292(4631)
TW-2400	2400(9084)	480	72(1829)	80(2032)	76(1930)	1103(496)	11695(5263)
TW-3000	3000(11355)	600	72(1829)	84(2134)	86(2184)	1503(676)	14013(6306)
TW-3400	3400(12869)	680	72(1829)	84(2134)	96(2438)	1540(693)	16082(7237)
TW-3800	3800(14383)	760	72(1829)	84(2134)	108(2743)	1590(715)	17738(7982)
TW-4200	4200(15897)	840	72(1829)	84(2134)	118(2997)	1800(810)	19807(8913)
TW-4600	4600(17411)	920	72(1829)	84(2134)	128(3251)	1900(855)	21876(9844)
TW-5000	5000(18925)	1000	72(1829)	84(2134)	136(3454)	2015(907)	23531(105889)

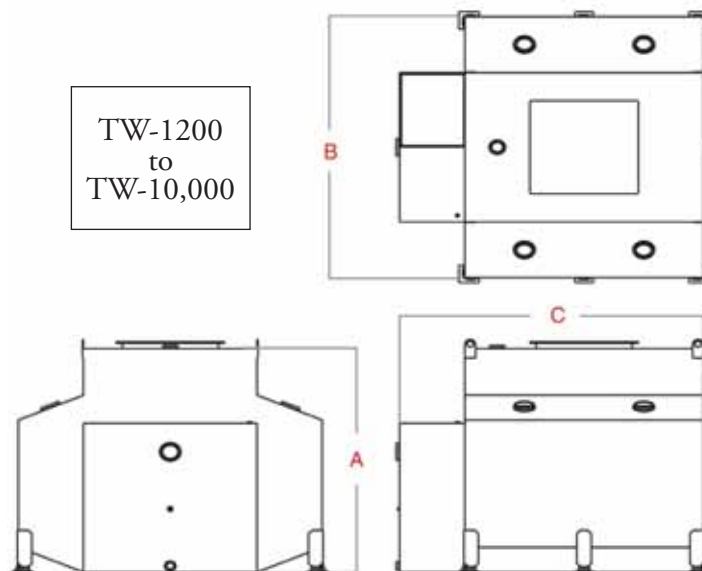

Contact Headhunter engineers for systems larger than 5000 GPD

Treatment System Control Panels

Tidal Wave Control Panels



Tidal Wave electrical control panels are designed to simplify the installation of our treatment system's electrical components and other accessories that may be required. All Tidal Wave electrical control panels are built with the latest, industrial grade GE switches, contactors and motor controllers. These motor controllers are listed under UL 508 as manual motor starters and comply with IEC international standards, for worldwide application. GE motor controllers provide Class 10 thermal overload protection, easy current adjustment, and a start, stop, rocker switch with trip indication. All panels provide circuit protection and motor control for the blower, and chemical injection pump used on every treatment system. In addition, the panels shown below provide automated sewage transfer and discharge functions as required by the installed location of the treatment system.



TWCP-BWL Tidal Wave Control Panel

Complete circuit management for the MSD blower, MSD chemical injection pump, and effluent discharge pump. This electrical panel is used when the toilets flush directly into the Tidal Wave MSD. Includes a complete Tank Sentry WTS-1500B for monitoring the final chamber, the disinfection chamber, of the MSD and automatically activating a discharge pump.

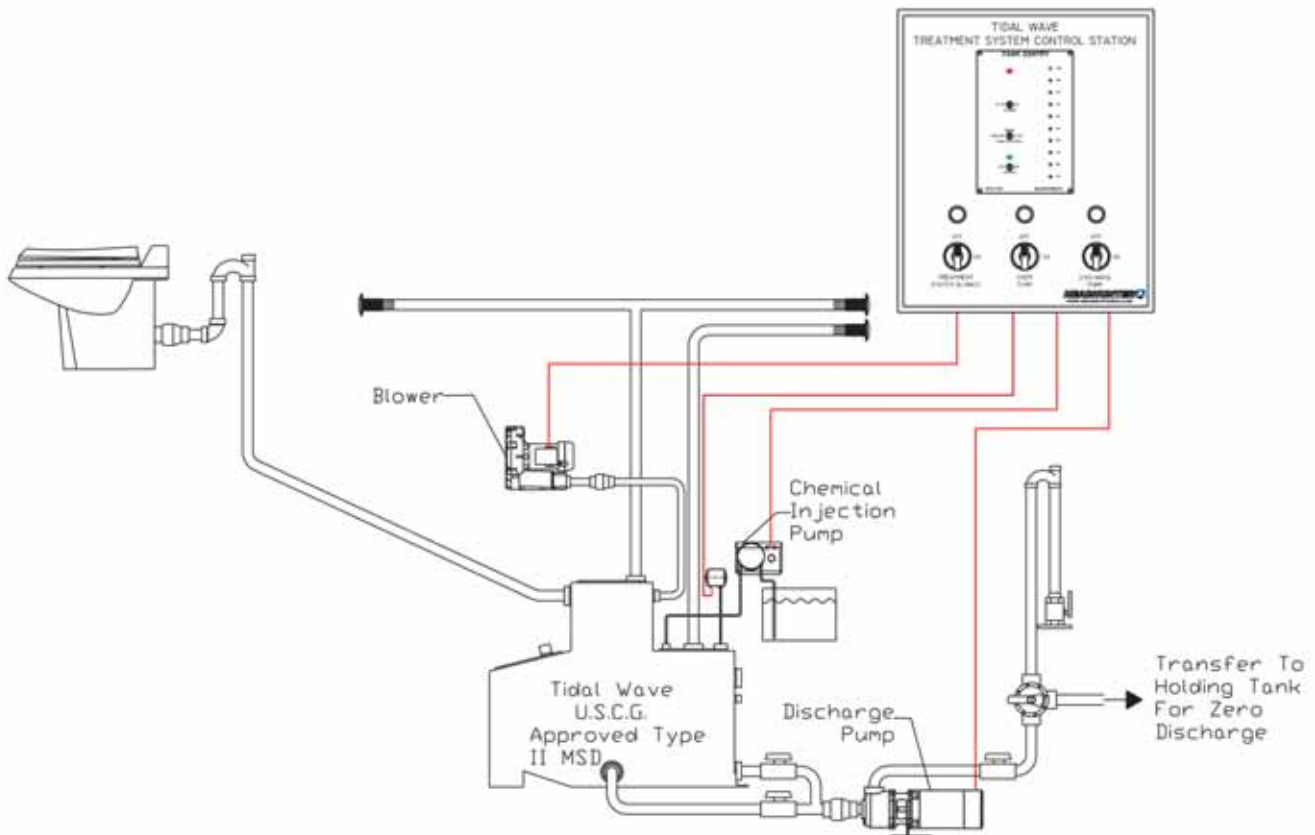

Treatment System Control Panels

TWCP-AWL Tidal Wave Control Panel

Complete circuit management provided for the holding tank blower, sewage transfer pump, MSD blower, and MSD chemical injection pump. This electrical panel is used when the toilets flush directly into an aerated holding tank, and the sewage is transferred to the Tidal Wave MSD, which is installed above the waterline. Includes a complete Tank Sentry WTS-1500B for monitoring holding tank level, interfaced with a timing relay to automate sewage transfer into the MSD.

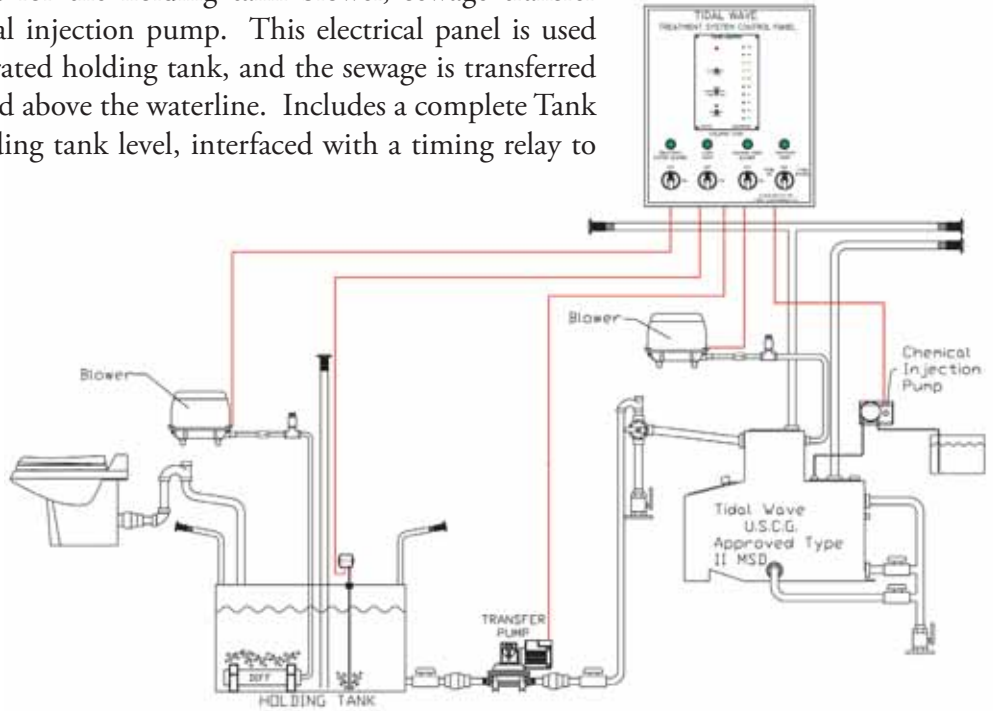

TWCP-BBWL Tidal Wave Control Panel

Complete circuit management for a holding tank blower, sewage transfer pump, MSD blower, MSD chemical injection pump, and effluent discharge pump. This panel is used on installations where the toilet flush into an aerated holding tank, and the sewage is transferred into a Tidal Wave MSD that is installed below the waterline. Includes a complete Tank Sentry WTS-1500B for monitoring holding tank level, interfaced with a timing relay to automate sewage transfer into the MSD. Includes a complete Tank Sentry WTS-1500B for monitoring the final chamber, the disinfection chamber, of the MSD and automatically activating a discharge pump.

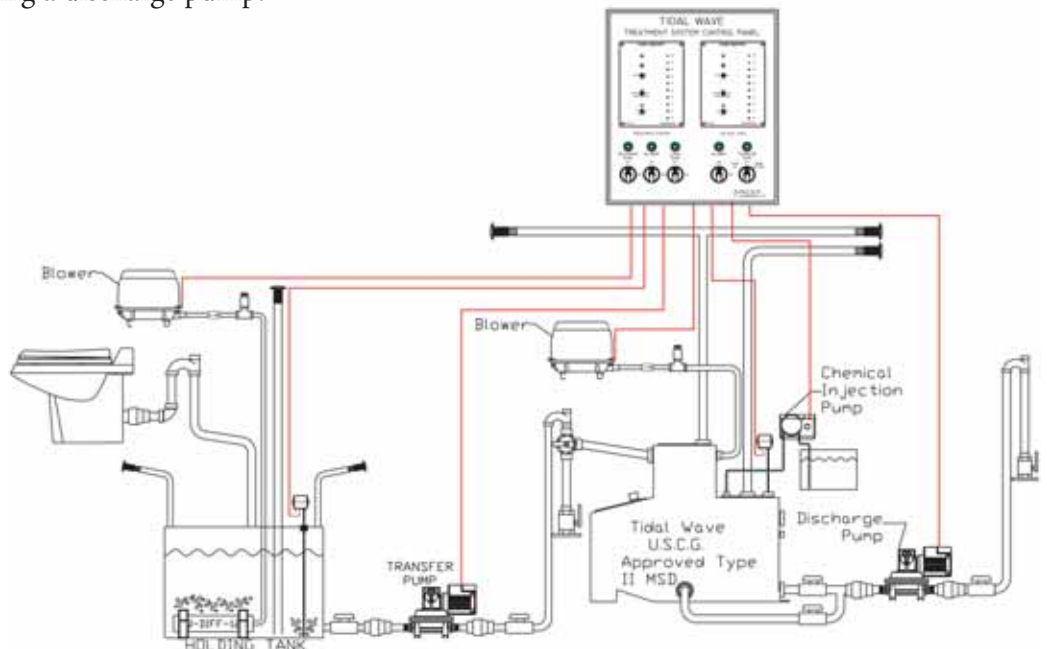

Waste Water Accessories

AUTO CLOR

marine hypochlorinator

- Self cleaning
- Safe to operate
- Low maintenance
- No extra chemicals or metering pumps required.
- Coated Titanium electrodes ensure maximum productivity

The AUTO CLOR is a rugged electrolytic chlorine generator system, specifically engineered for marine and offshore applications. Pulsed water flow yields controlled concentrations of chlorine-equivalent sodium hypochlorite produced through the decomposition of salt water in the electrolytic cell. The AUTO CLOR is primarily used to generate disinfectant for MSDs, and STPs. The proprietary design of the AUTO CLOR III and IV features microprocessor controlled operation of the key components with polarity reversing power supply in a compact package.

Auto Clor III

Dry weight: 22 lbs.
 Operation Weight: 26 Lbs.
 Input Power: 1 Amp @ 120VAC 50/60hz
 0.5Amp @ 208-240VAC 50/60hz
 Chlorine Production: 0.5 lbs. per day maximum
 Minimum Salinity: 3 ppt
 Minimum Temperature: 50 F (10 C)

Auto Clor IV

Dry weight: 24 lbs.
 Operation Weight: 28 Lbs.
 Input Power: 3 Amp @ 120VAC 50/60hz
 1.5Amp @ 208-240VAC 50/60hz
 Chlorine Production: 3 lbs. per day maximum
 Minimum Salinity: 3 ppt
 Minimum Temperature: 50 F (10 C)

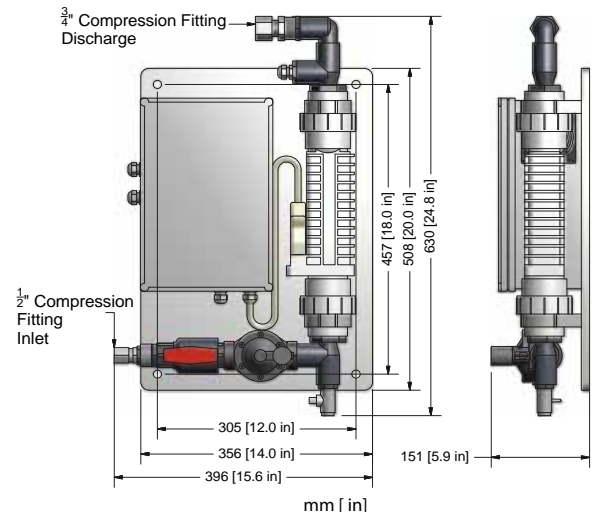

Ozone Generator

Our ozone generators create powerful and reactive oxidizers on-site, neutralizing odors and killing bacteria and mold. The ozone oxidizes organics and suspended solids, causing easier solids separation, and clearer effluent.

The OZ-1 and OZ-2 help to efficiently manage shipboard wastewater systems by diffusing the O3 in liquid and releasing the residual through the tank's vent system. The Ozone does two things when diffused in shipboard wastewater systems. It causes solids to separate from the liquid and reduces foul odors that may be generated in these tanks. When ozone is used in conjunction with chlorine in the chlorine contact chamber of the sewage treatment system, it helps oxidize the Total Suspended Solids (TSS) portion of the waste effluent, which results precipitation (separation of those solids from the water) and a reduction of combined chlorines. The result is a clearer effluent. The ozone that is released at the surface in the contact chamber is passed through the vent system connected to the treatment system helping to eliminate any unpleasant odor that could develop in the vent piping due to the moist warm conditions that exist in these pipes.



OZ-1 Provides an air Flow of 8 ft /hr with a Max Production of 8 Grams O3 daily.
 15-1/2" (394mm) L x 9-1/8" (232mm)W x 3-5/8" (92mm) H
 OZ-1(115) 115 VOLT, 60HZ Ozone Generator Kit
 OZ-1(230) 230 VOLT, 60HZ Ozone Generator Kit
 OZ-1(230/50) 230 VOLT, 50HZ Ozone Generator Kit
 OZ-1DIFF Diffuser Stone for In-tank Installation



OZ-2 Provides an air flow of 20 ft /hr with a Max Production of 24 Grams O3 daily.
 20-1/16" (511mm) L x 8-1/2" (216mm)W x 9-1/4" (235mm) H
 OZ-2(115) 115 VOLT, 60HZ Ozone Generator Kit
 OZ-2 Universal Voltage range 210 to 280 VAC @ 50/60 Hz Ozone Generator Kit
 OZ-2DIFF Diffuser Stone for In-tank Installation

Waste Water Accessories



Three Way Valve

This heavy duty valve is constructed of schedule 80 CPVC. It accepts 1-1/2" or 2" PVC pipe, or 1-7/8", and 1-1/2" hose (fittings included). Valve is full flow with no restrictive bends or constrictions. Handle may be locked or removed to meet U.S Coast Guard requirements for securing the system. Includes removable mounting feet shown.
6-1/2" (165mm) L x 7-1/8" (181mm)W x 6-1/2" (165mm) H

TW-1515 Headhunter Universal Three Way Valve w/Mounting Hardware



Swing Check Valves

Headhunter clear PVC swing check valves are handy installation accessories for piping systems. They are perfect for improving efficiency in sewage diaphragm pumps and preventing back flow. The transparency of the material also helps in troubleshooting and visual inspection. Installation is a breeze with standard PVC cleaner and glue.

SCV-1000C 1" Clear Swing Check Valve
SCV-1250C 1-1/4" Clear Swing Check Valve
SCV-1500C 1-1/2" Clear Swing Check Valve
SCV-2000C 2" Clear Swing Check Valve



Polyethylene Tanks

Headhunter has over one hundred polyethylene holding tanks, water tanks, and chemical storage tanks from 3 to 175 gallons available for rapid delivery. All fittings are installed per your specifications. We also carry a large selection of non-rectangular tanks. Sizes up to 12,000 gallons available by special order.

Call Headhunter to request our polyethylene tank catalog or visit our website for an quick and easy download.



2" Basket strainer

Headhunter offers a 2in basket strainer to prevent inorganic trash from entering the treatment system. The clear body and easy to use top makes trash removal quick and efficient.

- CLEAR EASTAR (PETG) CONSTRUCTION
- PVC CONECTIONS AND HUBS
- 2" SOCKET AND FPT HUBS PROVIDED
- STAINLESS STEEL BASKET WITH 3/8" PERFORATIONS

TW-HMX-BS 2" Clear Basket Strainer
13-1/2" (343mm)D (Largest Diameter) x 15-1/2" (394mm) H



The Grease Grouper

the ultimate grease extractor

The galley of today's luxury and commercial vessel creates just as much kitchen waste as a busy restaurant. The overboard discharge of food and grease is regulated and described by the IMO in Annex V of Marpol, and by the USCG in 33 CFR 151 regulations. The discharge of food and grease into a ships tank may clog the ship's piping and the accumulated material in a ship's tank will cause significant odor problems. The Grease Grouper eliminates this headache by recovering all food scraps and nearly 100% of the grease, oils, and fats from the galley wastewater. It prevents costly drain clogging, and protects on board sewage treatment systems and holding tanks. . The Grease Grouper ensures compliance by trapping food wastes & grease before discharge; it also keeps food wastes out of your tanks for effective odor control. Compact and easy to install. The Grease Grouper is the perfect solution. It's operation is programmable and available in 115 VAC, 230 VAC/50 Hz, and 230VAC/60 Hz.

- Rugged 304 SS construction
- Reliable programmable operation
- Reduces onboard maintenance of grey water collection systems

Model	GPM (lps)	Inlet/Outlet
GG20	20 (1.26)	2" (50mm)
GG25	25 (1.58)	2" (50mm)
GG35	35 (1.89)	2" (50mm)

Waste Water Pumps



Solids Handling Diaphragm Pump

- Self-priming to 10 Ft
- 1-1/2" Male NPT Inlet - 1-1/2" Female NPT Discharge
- Dry Run Capability
- Reinforced Polypropylene Construction
- Neoprene Diaphragms and Valves
- 316 Stainless Steel Shaft and Hardware
- Washdown Duty Motors

PART #	VOLTAGE	AMPS	Breaker Size
TORTUGA PUMP 1/2 HP Self Priming Diaphragm Pump			
TOR-12	12VDC	24	45
TOR-24	24VDC	12	25
TOR-1P60	115/230 VAC 1ph 60hz	8.8/4.4	15/10
TOR-1P50	220VAC 1ph 50hz	3.2	5
TOR-3P60	208-230/440 VAC 3ph 60hz	2.0/1.0	5
TOR-3P50	220/380/440 VAC 3ph 50hz	2.0/1.0	5

The Tortuga is an aggressive solids handling diaphragm pump constructed of a lightweight corrosion proof glass reinforced polypropylene. This pump is ideal for sewage, gray water, fish box and bilge applications where reliability is a premium. Its' solids handling and self-priming properties make it ideal for transferring waste from holding tanks into sewage treatment systems or overboard. All pumps are equipped with 1-1/2 inch NPT fittings for fast, easy installation.

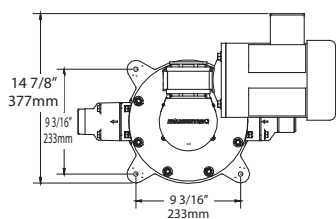

Plan View

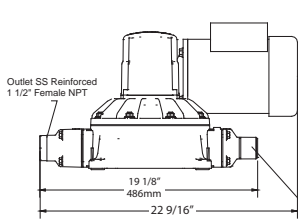

Elevation View

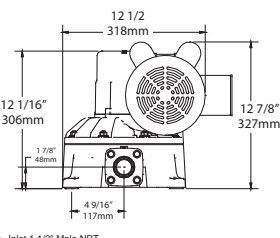

End View

PERFORMANCE

Delivery (Flow):	10 GPM (38 lpm)
Max Suction lift:	10 ft. (3 m)
Max Discharge (Head):	15 ft. (4.6 m)
Weight:	43 lbs (19.5 kg)



diaphragm pump

- Quiet diaphragm operation
- Able to pass large solids
- Can run dry without damage
- 12 foot suction lift capability
- 2" inlet and discharge standard
- 10 foot discharge head
- TEFC Motor

These pumps are the ultimate sewage handling pumps. They get the tough jobs done quickly, quietly, and reliably. Ideal for holding tank discharge applications, transfer systems, and for batching sewage into our Tidal Wave Type II MSD's. These pumps are an engineer's dream with their rugged construction and non-clogging flow-thru design. They make a great emergency bilge pump and are also ideal for industrial applications such as ground water remediation, abrasive fluid transfers, and dewatering.

SPECIFICATIONS

Electric motor (12/24V DC, 115 / 208 - 230V AC), or air powered. Other electric motor voltages available, just ask. Standard bronze construction.

Model	Flow Rate GPM (lpm)	Voltage	Amps	Discharge Size	Construction
Electric Powered					
120ELB20AC200	20 (76)	115/208-230V AC	7.4/3.8	2"	Bronze/Hypalon
120ELB2012200	20 (76)	12VDC	50	2"	Bronze/Hypalon
120ELB2024200	20 (76)	24VDC	25	2"	Bronze/Hypalon
Repair Kit					
114N117120	Bone Dry Hypalon Repair Kit*				

*Repair Kits consist of a replacement diaphragm, two valve assemblies, and two sealing washers.

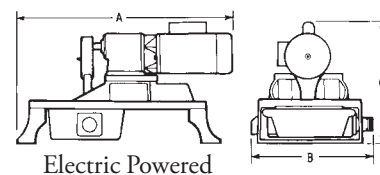

A.Length	30-3/4" (78.1 cm)
B.Width	17" (43.2 cm)
C.Height	16-1/2" (41.9 cm)
D.Weight	112 lbs (51 kg)

Waste Water Pumps



THR - Thresher Discharge Pumps are perfect for applications involving holding tanks, gray water tanks, or discharge from sewage treatment systems, the Thresher is designed

to thrash through wastewater. The marine composite pump body and impeller slurries waste, passes large solids, and runs dry without damage. The 316 stainless steel shaft and mechanical seal provides years of dry, trouble free service. THR-HMX - Thresher Pumps with 1 hp -1750 RPM motors are used in all TidalWave HMX Sewage Treatment Systems to provide continuous sewage circulation and maceration.

- Passes solids up to 1-1/4" diameter
- Composite pump body & impeller, 316 SS pump shaft & seal
- 2" FPT connections stainless steel reinforced Suction & Discharge
- Max discharge of 30' (9m)
- Max flow of 60 GPM (227 lpm)
- Requires flooded suction
- 40 lbs (18 kg)
- TEFC Washdown motor standard - other IP-56 and explosion proof options available.

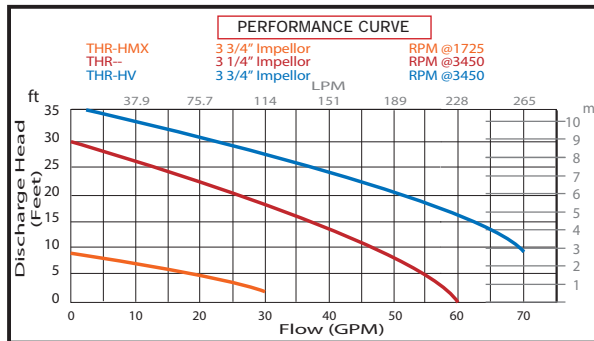
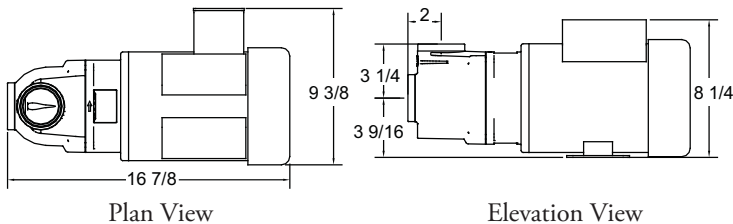

PART #	DESCRIPTION	VOLTAGE	AMPS	RPM	Impellor
THRESHER VORTEX SEWAGE DISCHARGE PUMPS					
THR-1P60	3/4 HP PUMP	115/230 VAC 1ph 60hz	10/5.2-5	3450	3 1/4"
THR-1P50	3/4 HP PUMP	220VAC 1ph 50hz	5.6	2850	3 1/4"
THR-3P50	3/4 HP PUMP	220/380VAC 3ph 50hz	3/1.75	2850	3 1/4"
THR-3P60	3/4 HP PUMP	230/380VAC 3ph 60hz	2.5-2.4/1.2	3450	3 1/4"
THR-12	3/4 HP PUMP	12VDC -Special Order	58	3000	3 1/4"
THR-24	3/4 HP PUMP	24VDC -Special Order	30	3000	3 1/4"
THR-CIRC-1P60	1 HP PUMP	115/230 VAC 1ph 60hz	12/6.2-6	3450	3 1/4"
THRESHER HMX VORTEX SEWAGE PUMPS					
THR-HMX-1P60	1 HP PUMP	115/230 VAC 1PH 60hz	12.8/6.4	1725	3 3/4"
THR-HMX-1P50-3.25	1 HP PUMP	220VAC 1ph 50hz	13.2/6.6	2850	3 1/4"
THR-HMX-3P50-3.25	1 HP PUMP	220/380VAC 3ph 50hz	4.2/2.4	2850	3 1/4"
THR-HMX-3P50-3.25-IP56*	3/4 HP PUMP	190/380VAC 3ph 50hz	2.4/1.2	2850	3 1/4"
THR-HMX-3P60	1 HP PUMP	230/380VAC 3ph 60hz	3.6-3.8/1.9	1725	3 3/4"
THR-HMX-HV-3P60	3 HP PUMP	208-230/440VAC 3ph 60hz	8.1-7.6/3.8	3450	3 3/4"
HIGH VOLUME THRESHER VORTEX SEWAGE PUMPS					
THR-HV-1P60	2 HP PUMP	115/230 VAC 1PH 60hz	20/11.4-10	3450	3 3/4"
THR-HV-3P60	2 HP PUMP	230/380VAC 3ph 60hz	5.7-5.4/2.7	3450	3 3/4"
THR-3P50-3.75-IP56-SS*	1 1/2 HP PUMP	190/380VAC 3ph 50hz	5.8/2.9	2900	3 3/4"

*CIRC = Circulation HV = High Volume

* Note: HV motor length may vary

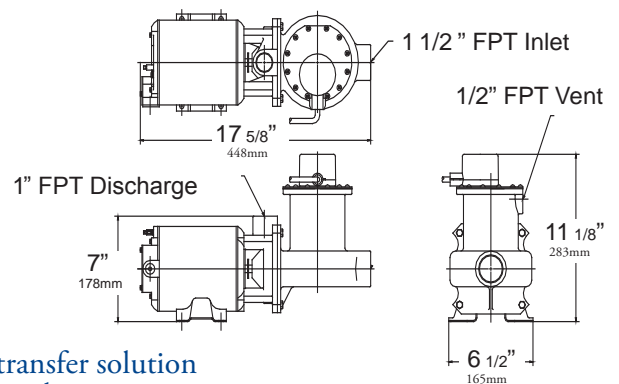

- Quick & easy gray water transfer solution
- High flow and discharge head capacity
- Quiet operation
- TENV Motor

The Coho provides an easy and compact solution for movement of gray water onboard. It's a combined receiving tank, discharge pump, and motor controller all in one. Just bolt it in and hook up the pipes.

Weight: 27 lbs.

Model	Voltage	Amps	Discharge Head ft (m)		
			5 (1.5)	10 (3.0)	15 (4.6)
Flow in GPM (lpm)					
COHO-AC	115V/230V 50/60hz	7/3.5	31 (117)	25 (95)	18 (68)

Note: Flow rates at 60 hz operation

Waste Water Pumps

Lift Stations

Lift stations available in custom sizes, are constructed of steel or 5083 aluminum. All types of options available, from submersible pumps that are platform-mounted and attached to the lid for easy removal to skid mounted corrosion proof poly tanks, and explosion proof pumps. All have a ceramic coating inside and out for long life. Programmable control box permits monitoring of fluid level.

Call Headhunter for your particular application.



Custom Lift Station with Lid Mounted Pump



HHLS

Automatic sewage transfer system comprising 12 gallon polyethylene tank; composite sewage pump; vertical sump switch to automate the operation; gasketed P.V.C access hatch with SS fasteners. System also includes a secondary, pneumatically operated high level switch with normally open and normally closed connections to interface with our MO-4000 or a ship's monitoring system. Wt. 32lbs.(14.5kg)

Pump Specifications

	HHLS-115	HHLS-230/60	HHLS-230/50
Power	115V	230V	230V
	60Hz	60Hz	50Hz
Watt	330	330	330
Amp	2.8	1.4	1.4

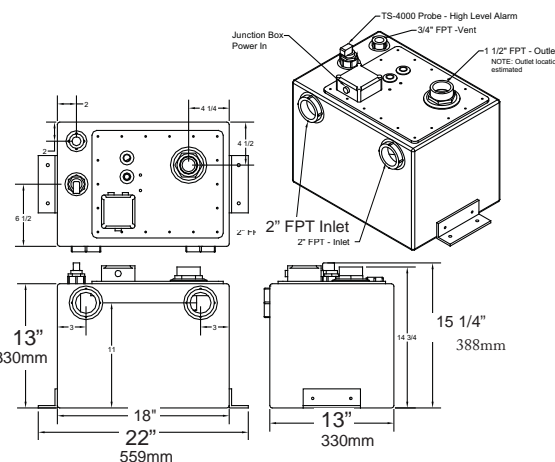
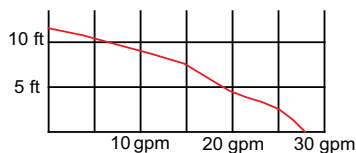

Hose



Applications

- Black Water Discharge & Transfer • Toilet Pressure Supply • Holding Tank Vents • Freshwater Tank Vents • Freshwater Suction and Pressure Distribution • Gray Water Drains • Gray Water Tank Vents

Features

- Super Flexible Construction
- Superior Odor Impermeability.
- Exceeds the specification of NSF 61 drinking water system components
- Max Temperature: 200F (94C). Will not degrade in high temperature engine room environments.
- EPDM Shell: Provides superior Ozone resistant external liner
- BUTYL Shell: Provides a smooth anti-microbial food grade inner liner.

Headhunter Great White™ Super Premium Water/Sanitation Hose is an engineered hose developed especially for the rigors of the harsh marine environment. A specially formulated liner constructed of anti-microbial food quality butyl polymer provides an impermeable odor barrier. A double steel wire helix and high tensile fabric reinforcement provide extreme flexibility for ease of installation and a snow white EPDM abrasion resistant jacket provide superior Ozone resistance not found in conventional sanitation hoses.

No.	I.D.	Working Pressure	Bending Radius	Coil Length
GWH-750	3/4" (19mm)	100psi (7 Bar)	2" (50mm)	100 ft. (30.48mt)
GWH-1000	1" (25mm)	100psi (7 Bar)	3" (75mm)	100 ft. (30.48mt)
GWH-1500	1 1/2" (38mm)	100psi (7 Bar)	3 1/2" (90mm)	50 ft. (15.24mt)
GWH-1780	1 7/8" (48mm)	100psi (7 Bar)	5 1/4" (134mm)	50 ft. (15.24mt)
GWH-2000	2" (51mm)	100psi (7 Bar)	6" (153mm)	50 ft. (15.24mt)

Consumables



Breeze

BOWL CLEANER

Cleaning toilets is a Breeze with this new biologically active formula. Breeze contains special enzymes and microorganisms in a super effective mixture engineered to give toilets, sinks, and showers a fresh gleam, clean smell and brilliant shine. Put Breeze's unique mix of waste-degrading bacteria and cleaning agents to work on all your bathroom surfaces and improve the performance of your biological sewage treatment at the same time. Available in one quart bottle, twelve bottles per case.



Reveille

BIO-WASTE DEGRADER

WAKE UP THE POWER OF NATURE!

Reveille contains over 3/4 million microorganisms per ounce. Scientifically designed to digest wastes, clear drains, and eliminate offensive odors. Optimizing the performance of your sanitary system has never been easier. Simply pour Reveille into drains, shower sumps, toilets, and holding tanks. No mess, no fuss. Available in 22 ounce bottle, twelve bottles per case.



Finally, a wastewater disinfectant that is safe and easy to prepare. Disinfection is a necessary step in all wastewater treatment systems. When dropped in a tank of water, this tablet fizzes to dissolve and mix itself, thus creating a safe, non-caustic, and non-irritating disinfectant solution. This solution is injected into the final stage of our Marine Sanitation Device. These tablets are compact, release no odor while in storage and are safe for air transport. This sanitizer is the product of choice for killing those nasty fecal coliform and other pathogenic bacteria, viruses, and offensive odors. One jug with 100 tablets will last for over one year when used with our 50 gal/day sewage treatment system.

EfferSan 100 100 Tablet Container



Put a predator in your tank

An all-natural specialized blend of bacterial cultures and nutrients specifically selected for their ability to degrade typical marine and institutional sewage. This synergistic mix of facultative bacteria (both aerobic & anaerobic bacteria) generates a variety of enzymes to help break down starch, fat, oil, grease, protein, and cellulose found in the waste stream. Reduce odors and solids, and improving biological activity in your sewage treatment system the natural way. For peak treatment system performance flush four one ounce bags / 50 gallons of treatment capacity at startup, and add one additional pouch every two weeks. Available in a 20-count plastic container.

Piranha 20 20 pack bottle

CRYSTALLINE

SEWAGE CONDITIONING POWDER & TABLETS



Crystalline is a proprietary dry chemical agent that is mixed with water to form a sewage conditioning solution. Available in powder or tablet form. The Crystalline sewage conditioning solution is the initial part of the entire 2010 Tidal Wave HMX process. Crystalline is safe to handle, ship, and transport and is available in 40 lb buckets.

Crystalline Powder in 40 lb bucket
Part # TW-HMX-CD.140

Crystalline Toilet Tablets with 10 toilet baskets in 40 lb bucket
Part # TW-HMX-CDT.140

COCO CLEAN

Effluent Polishing Media



Coco Clean carbon media refill uses a specially designed granular carbon to mitigate chemical oxygen demand, chlorine, chlorine by-products, and odor from treated effluent while maximizing service intervals. Coco Clean is safe to handle, ship, and transport and is available in 3 gallon cartridge replacement 20 lb buckets and 200 lb. drums.

20 lb Bucket
Part # TW-HMX-CC.15

200 lb Drum
Part # TW-HMX-CC.200



TOILETS



**WATER
PRESSURE
SYSTEMS**

**WASTE
TREATMENT &
MANAGEMENT**



**FLUID
LEVEL
MONITORING**



**AND
MORE!**



HEADHUNTER 

3380 SW 11th Avenue
Fort Lauderdale, Florida 33315

www.Headhunterinc.com
e-mail: headmaster@headhunterinc.com

Phone: +1 954-581-6996
Fax: +1 954-587-0403